



MLA 150

LEGAL INFORMATION

Copyright © 2023 Heidelberg Instruments Mikrotechnik GmbH. All rights reserved.

Heidelberg Instruments Mikrotechnik GmbH reserves the right to make changes in specifications and other information contained in this document without prior notice. The technical specifications in this document depend on individual process conditions and may vary according to the equipment configuration. The information in this document does not represent a commitment on the part of Heidelberg Instruments Mikrotechnik GmbH.

Heidelberg Instruments Mikrotechnik GmbH shall not be liable for technical or editorial errors or omissions contained in this document; nor for incidental or consequential damages resulting from the furnishing, performance, or use of this manual.

This document contains proprietary information that is protected by copyright. No part of this document may be reproduced, stored in a retrieval system, or transmitted, in any form or by any means, without the prior written consent of Heidelberg Instruments Mikrotechnik GmbH.

Other product names and marks mentioned in this document may be trademarks or registered trademarks of other companies and are the property of their respective owners.

Doc. No.: HI-01492-UG03

Rev.-No.: 4 (September 2023)

[heidelberg-instruments.com](https://www.heidelberg-instruments.com)

Heidelberg Instruments Mikrotechnik GmbH
Mittelgewannweg 27, D-69123 Heidelberg
Phone: +49 6221 728899-0

Table of contents

1	Introduction	1
1.1	About this guide	2
1.1.1	Target audience.....	2
1.1.2	Symbols in this document.....	3
1.1.3	Designations in this document.....	3
1.2	Related documentation	5
2	Safety information	6
2.1	Intended use	6
2.2	Safety first	7
2.2.1	Electrical safety.....	7
2.2.2	Laser safety	8
2.2.3	Magnetic resonance safety.....	9
2.2.4	Occupational safety	10
2.3	Safety devices.....	11
2.3.1	Interlock	11
2.3.2	Emergency switches.....	11
2.4	Disposal	13
3	System	14
3.1	Front.....	15
3.2	Right.....	16
3.3	Interior	17
3.3.1	Base system	18
3.3.2	Stage system.....	19
3.3.3	Optics system	20
3.3.4	Backside alignment system	22
3.4	Environmental chamber	24
3.5	Electronics cabinet.....	25
3.6	Step-up transformer	25
3.7	Electronics.....	25
3.7.1	System network switch	26
3.7.2	Autofocus control rack.....	26
3.7.3	Power supply rack	26
3.7.4	Stage controller rack.....	26
3.7.5	Chiller.....	26
3.7.6	Conversion PC.....	27
3.7.7	User PC	27
3.8	Software	28
3.8.1	Conversion software.....	28
3.8.2	Control software.....	28
3.8.3	TeamViewer software	28

3.8.4	AnyDesk software	29
4	User interface	30
4.1	Primary window	30
4.1.1	Menu bar	31
4.1.2	Job Process Overview frame	32
4.1.3	Exposure Info frame	33
4.1.4	Alignment Info frame	34
4.1.5	Series Info frame	35
4.1.6	Progress Info frame	36
4.1.7	Hardware Info frame	37
4.1.8	Setup Job frame	38
4.1.9	Load Substrate frame	40
4.1.10	Load Series frame	42
4.1.11	Load Design frame	43
4.1.12	Load Exposure Bitmaps frame	45
4.1.13	Load Alignment Settings frame	46
4.1.14	Load Resist frame	48
4.1.15	Load Substrate <name> frame	50
4.1.16	Alignment frame	51
4.1.17	First Exposure frame	52
4.1.18	Alignment Exposure frame	53
4.1.19	Series frame	55
4.1.20	Draw Mode frame	56
4.1.21	Inspection Mode frame	57
4.1.22	Exposure History frame	58
4.1.23	Startup Info frame	59
4.1.24	Laser Measurement frame	60
4.1.25	Stage and Camera Control frame	62
4.2	Secondary window	64
4.2.1	Menu bar	65
4.2.2	Status bar	65
4.2.3	Cameras panel	65
4.2.4	<Device> Lamp panel	69
4.2.5	Overview Camera Controller panel	71
5	Turn on/off the system	73
5.1	Turn on the system	74
5.2	Put the system to standby mode	75
5.3	Shut down the system	75
5.3.1	Restart the system after emergency shut-off	76
6	Start/end work sessions	77
6.1	Start the software	77
6.2	Log in	77
6.3	Create jobs	77
6.4	Load jobs	78
6.5	Change users	78
6.6	Log out	79

7	Load/unload substrates	80
7.1	Load substrates.....	80
7.1.1	Load small substrates.....	80
7.1.2	Load medium-sized substrates.....	82
7.1.3	Load large substrates	84
7.2	Unload substrates	87
7.3	Exchange chucks	87
8	Execute exposures.....	90
8.1	Execute single-layer exposures	90
8.1.1	Set up jobs.....	90
8.1.2	Load substrates	92
8.1.3	Set up exposure parameters	93
8.1.4	Execute exposures	94
8.2	Execute multi-layer exposures.....	95
8.2.1	Set up jobs.....	101
8.2.2	Load substrates	102
8.2.3	Set up exposure parameters	103
8.2.4	Execute exposures	104
8.2.5	Set up layers.....	105
8.2.6	Load substrates	106
8.2.7	Set up global alignment parameters	107
8.2.8	Execute alignments	108
8.2.9	Set up exposure parameters	112
8.2.10	Execute exposures	113
8.3	Execute field-aligned exposures	114
8.3.1	Set up jobs.....	115
8.3.2	Load substrates	117
8.3.3	Set up exposure parameters	118
8.3.4	Execute exposures	119
8.3.5	Set up layers.....	120
8.3.6	Load substrates	121
8.3.7	Set up global alignment parameters	122
8.3.8	Execute alignments	123
8.3.9	Set up exposure parameters	127
8.3.10	Set up field alignment parameters	128
8.3.11	Execute alignments	129
8.3.12	Execute exposures	129
8.4	Execute exposure series.....	130
8.4.1	Set up jobs.....	130
8.4.2	Load substrates	132
8.4.3	Set up exposure parameters	132
8.4.4	Execute exposures	135
8.5	Execute ad hoc shape exposures.....	135
8.5.1	Set up jobs.....	135
8.5.2	Load substrates	137
8.5.3	Set up exposure parameters	138

8.5.4	Draw shapes	138
8.5.5	Execute exposures.....	142
8.6	Find substrate centers.....	143
8.7	Check logs.....	144
9	Set up templates	145
9.1	Set up substrate templates	145
9.2	Set up resist templates.....	149
9.3	Set up bitmap templates	151
9.4	Set up alignment templates.....	152
9.5	Set up field alignment templates	154
9.6	Set up series templates.....	155
10	Execute calibrations	158
11	Troubleshooting.....	161

List of illustrations

Fig. 1: Orientation sketch.....	4
Fig. 2: Emergency shut-off switch	12
Fig. 3: Emergency shut-off safety label	12
Fig. 4: System components	14
Fig. 5: Front of the machine.....	15
Fig. 6: Right side of the machine	16
Fig. 7: Temperature controller	16
Fig. 8: Interior of the machine	17
Fig. 9: Operator panel.....	19
Fig. 10: Stage coordinate system	19
Fig. 11: Camera coordinate system.....	20
Fig. 12: Backside alignment marks on the lower surface	22
Fig. 13: Chuck – Backside alignment zones (standard chuck layout)	23
Fig. 14: Electronics cabinet (exemplary picture).....	25
Fig. 15: Conversion of design data and design processing	27
Fig. 16: Control and data processing.....	27
Fig. 17: Main window	30
Fig. 18: Job Process Overview frame.....	32
Fig. 19: Exposure Info frame	33
Fig. 20: Alignment Info frame	34
Fig. 21: Series Info frame	35
Fig. 22: Progress Info frame	36
Fig. 23: Hardware Info frame	37
Fig. 24: Setup Job frame	38
Fig. 25: Load Substrate frame	41
Fig. 26: Load Series frame	42
Fig. 27: Load Design frame	43
Fig. 28: Load Exposure Bitmaps frame	45
Fig. 29: Load Alignment Settings frame	46
Fig. 30: Load Resist frame	48
Fig. 31: Load Substrate <name> frame	50
Fig. 32: Alignment frame	51
Fig. 33: First Exposure frame	52
Fig. 34: Alignment Exposure frame	54
Fig. 35: Series frame	55
Fig. 36: Draw Mode frame	56
Fig. 37: Inspection Mode frame	58
Fig. 38: Exposure History frame	59
Fig. 39: Startup Info frame.....	60
Fig. 40: Laser Measurement frame	61
Fig. 41: Stage and Camera Control frame.....	62
Fig. 42: Stage and Camera Control frame – Camera Control frame	62
Fig. 43: Stage and Camera Control frame – Stage Control frame	63
Fig. 44: Secondary window	64
Fig. 45: Cameras panel	66
Fig. 46: Cameras panel – Camera frame	68
Fig. 47: <Device> Lamp panel.....	69
Fig. 48: <Device Lamp> panel – Lamp Control frame.....	70
Fig. 49: Overview Camera Controller panel	71

Fig. 50: <Device Lamp> panel – Overview Camera Control frame	72
Fig. 51: Main switch at the step-up transformer	73
Fig. 52: Power controls at the power supply rack	73
Fig. 53: Place the adjustment aid for small substrates	81
Fig. 54: Place the substrate in the adjustment aid	81
Fig. 55: Remove the adjustment aid.	81
Fig. 56: Correctly aligned substrate	81
Fig. 57: Place the adjustment aid for medium-sized substrates	82
Fig. 58: Align the adjustment aid.....	83
Fig. 59: Align the substrate	83
Fig. 60: Correctly aligned substrate	83
Fig. 61: Remove the adjustment aid.	84
Fig. 62: Place the adjustment aid for large substrates	85
Fig. 63: Align the substrate	85
Fig. 64: Remove the adjustment aid.	86
Fig. 65: Correctly aligned substrate	86
Fig. 66: Standard chuck	87
Fig. 67: Pneumatic clamp switch	88
Fig. 68: Pneumatic clamp	88
Fig. 69: Place the chuck in the frame.....	89
Fig. 70: Multi-layer exposure.....	95
Fig. 71: Multi-layer exposure.....	95
Fig. 72: Alignment of multiple layers	96
Fig. 73: Example of alignment mark design and placement	97
Fig. 74: Backside alignment marks on the lower surface.....	97
Fig. 75: Infrared backside alignment with alignment marks on the upper surface	98
Fig. 76: Global alignment	99
Fig. 77: Field alignment.....	99
Fig. 78: Global alignment	100
Fig. 79: Camera – Manual Alignment – Alignment center frame	110
Fig. 80: Camera – Angle – Before adjustment.....	111
Fig. 81: Camera – Angle – After adjustment.....	111
Fig. 82: Field alignment – Designs aligned to field alignment marks	114
Fig. 83: Field alignment – Global alignment marks	114
Fig. 84: Field alignment – Field alignment marks	115
Fig. 85: Field alignment – Indexes and field coordinate systems	115
Fig. 86: Camera – Manual Alignment – Alignment center frame	125
Fig. 87: Camera – Angle – Before adjustment.....	126
Fig. 88: Camera – Angle – After adjustment.....	126
Fig. 89: Exposure Series – Expose Labeling	134
Fig. 90: Camera – Draw Image.....	139
Fig. 91: Camera – Draw Image – Ad hoc shapes	140
Fig. 92: Camera – Draw Line or Polygon – Set Point	141
Fig. 93: Camera – Acquire Position	143
Fig. 94: Load Resist frame – Grayvalue Optimization frame	150
Fig. 95: Vernier scale in FAT test pattern	158
Fig. 96: Beam Offset dialog – Calculated beam offset.....	160

List of tables

Tab. 1: Symbols in this document	3
Tab. 2: Designations in this document	3
Tab. 3: Magnetic fields	10
Tab. 4: Backside alignment – Alignment mark positions – Examples	23
Tab. 5: Primary window – Menu bar	32
Tab. 6: Job Process Overview frame – Control and display objects	32
Tab. 7: Exposure Info frame – Display objects	33
Tab. 8: Alignment Info frame - Frames	34
Tab. 9: Alignment Info frame – Display objects	34
Tab. 10: Series Info frame – Display objects	36
Tab. 11: Progress Info frame – Display objects	36
Tab. 12: Hardware Info frame – Header – Control and display objects	37
Tab. 13: Hardware Info frame – Status frame – Display objects	37
Tab. 14: Hardware Info frame – Numeric Values – Display objects	38
Tab. 15: Setup Job frame – Control and display elements	40
Tab. 16: Setup Job frame – Tables – Color highlighting	40
Tab. 17: Load Substrate frame – Control and display elements	42
Tab. 18: Load Series frame – Control and display elements	43
Tab. 19: Load Designs frame – Control and display elements	44
Tab. 20: Load Expose Bitmaps frame – Control and display elements	46
Tab. 21: Load Alignment Settings frame – Control and display elements	48
Tab. 22: Load Resist frame – Control and display elements	49
Tab. 23: Load Substrate <name> frame – Control and display elements	51
Tab. 24: Alignment frame – Control and display elements	52
Tab. 25: First Exposure frame – Control and display elements	53
Tab. 26: Alignment Exposure frame – Control and display elements	55
Tab. 27: Series frame – Control and display elements	56
Tab. 28: Draw Mode frame – Control and display elements	57
Tab. 29: Inspection Mode frame – Control and display elements	58
Tab. 30: Exposure History frame – Control and display elements	59
Tab. 31: Startup Info frame – Control and display elements	60
Tab. 32: Laser Measurement frame – Control and display elements	61
Tab. 33: Camera Control frame – Control objects	63
Tab. 34: Stage Control frame – Control objects	64
Tab. 35: Secondary window – Menu bar	65
Tab. 36: Toolbars	68
Tab. 37: Camera frame – Control and display objects	69
Tab. 38: Control and display objects	70
Tab. 39: Lamp Control frame – Control and display objects	71
Tab. 40: Control and display objects	72
Tab. 41: Overview Camera Control frame – Control and display objects	72

1 Introduction

The MLA 150 is a high-speed, maskless direct-writing lithography system. Direct writing technology has the advantage of increasing the effective throughput as well as cost savings.

The system is developed to expose substrates with a photoresist coating. The exposure laser generates a sufficient dose to expose even thick and less sensitive resists. The system can process different substrate sizes. The system also provides pattern changes, distortion correction, and other software-driven corrections.

The system is equipped with one exposure laser. The exposure laser is a 375 nm ultraviolet laser diode.

The control software implements a graphical user interface. The control software allows to control and monitor the system and to set up and execute the applications.

The system uses the following control software: MLA Menu

The conversion software converts external file formats, such as DXF or GDS, into a machine-readable format. The machine-readable format is optimized for rapid processing by the system.

The system uses the following conversion software: APP

The system is equipped with a pneumatic autofocus. The pneumatic autofocus uses compressed air to regulate the distance between the write head and the substrate.

The system is equipped with an optical autofocus. The optical autofocus provides superior focus stability and enables the system to expose very small surfaces. The operator can switch between the autofocus modes to meet the individual requirements of the application.

The system supports top- and backside alignment with high accuracy. The backside alignment system is mounted below the stage. It is used to find alignment marks for layer alignments on the bottom surface of the substrate.

The system supports the high aspect ratio mode. The high aspect ratio mode enables the system to adjust the depth of the focus to optimize the sidewalls in thick photoresists.

The system is upgraded to support an extra-large exposure area. For more information about the dimensions of the exposure area and the supported substrate sizes, see the Technical Data Sheet.

Seismic anchors are available for the system upon customer request. Anchors are required if seismic risks must be considered. Always follow the regional regulations and recommendations for seismic anchorage.

1.1 About this guide

NOTE

This guide contains information about how to operate the system. For general information about the system or maintenance, see the documents already delivered with your system.

This guide provides information about the operation of the system and step-by-step instructions about how to use the system and how to perform standard operations.

This document addresses only the Heidelberg Instruments Mikrotechnik product and those supplementary components and peripherals provided by Heidelberg Instruments Mikrotechnik. Installations required at the facility to operate the machine may not be covered and therefore responsibility for the safety of those installations resides with the system owner.

Specifications are subject to change without notice. Every attempt has been made to make this document complete, accurate, and based on our recent knowledge and experience. However, deviations may occur, so no liability is assumed regarding complete agreement with the documentation.

The illustrations, photos, and screenshots are exemplary pictures and can deviate from the delivered products.

⚠ Safe use is ensured only if this manual is followed completely. Before working on or with the system, read this manual thoroughly.

1.1.1 TARGET AUDIENCE

This document is intended for qualified operating staff with professional knowledge in laser lithography systems and persons responsible for administering the system at the facility.

This document is for qualified personnel only. Qualified personnel have received training and have demonstrated skills and knowledge in the corresponding fields. Qualified personnel are trained to deal with the dangers and hazards involved in the operation of laser devices, to establish appropriate safety and health practices, and to determine the applicability of regulatory or other limitations prior use.

The person using the system must have read and understood the document and follow the instructions provided.

Maintenance and servicing of the system must be carried out only by properly qualified maintenance and service personnel and thereby is not subject to this document.

1.1.2 SYMBOLS IN THIS DOCUMENT

The following levels of warning messages may occur when handling the product:

⚠ DANGER	Indicates a hazardous situation that, if not avoided, will result in death or serious injury.
⚠ WARNING	Indicates a hazardous situation that, if not avoided, could result in death or serious injury.
⚠ CAUTION	Indicates a hazardous situation that, if not avoided, could result in minor or moderate injury.
NOTICE	Indicates a hazardous situation that, if not avoided, could result in property damage.

The definitions of the warning messages conform to ANSI Z535.6-2011 (R2017), SEMI S1-1015, and SEMI S13-0113.

The following messages may occur in this document:

NOTE	Indicates information that is important for a specific topic or goal but is not safety relevant.
-------------	--

The following symbols may occur in this document:

Symbol	Description
⚠	Indicates important information.
✓	Indicates desired results.
☐ / ☑	Indicates checklist items and requirements for meeting a specific goal.
↑	Indicates the front of a unit in drawings showing a top view or bottom view.
<...>	Indicates a placeholder for variable content.
\$	Indicates a sequence of one or more variable alphanumeric characters.
#	Indicates a sequence of one or more variable digits.

Tab. 1: Symbols in this document

1.1.3 DESIGNATIONS IN THIS DOCUMENT

Complete designation	Designation in this document
MLA150 system	system, product
Heidelberg Instruments Mikrotechnik GmbH	HIMT
purchaser of the system, contractors commissioned by the purchaser of the system	purchaser

Tab. 2: Designations in this document

The definitions *left* and *right* refer to the front view of the machine or units.

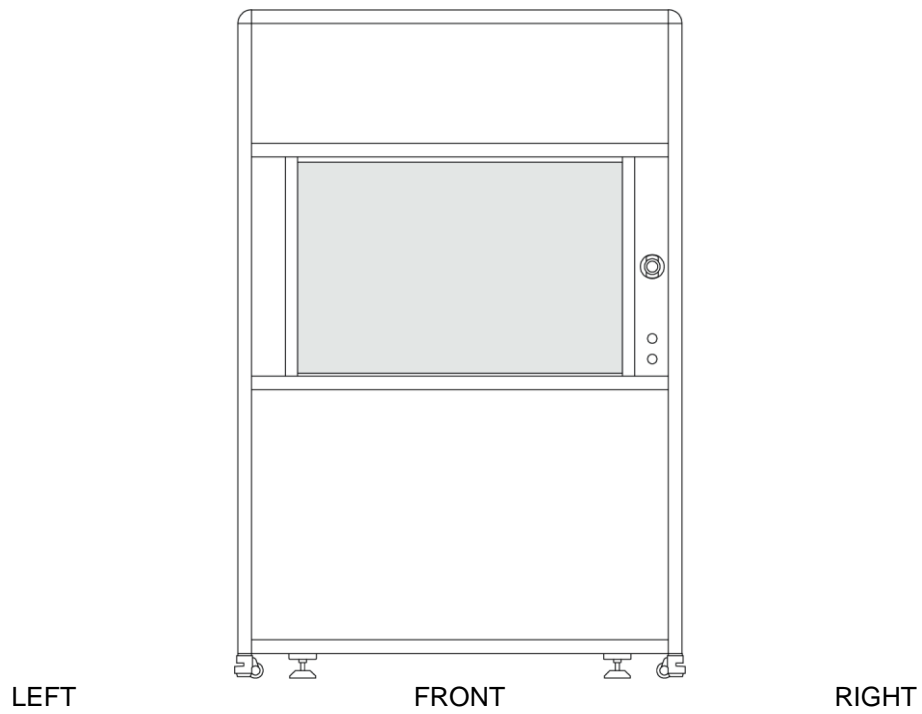

Fig. 1: Orientation sketch

1.2 Related documentation

The user manual consists of several related parts addressing the system configuration, safe and correct operation, and other important topics. If you did not receive any of the following user manual parts or if you want to order a replacement, contact Heidelberg Instruments Mikrotechnik, Germany.

Pre-installation Guide

This guide provides information about the system requirements and the system dimensions that are relevant for installing the system.

Safety Guide

This guide provides guidance on the safe use of the system including requirements for safe use and information about potential hazards (health, physical, and environmental).

Maintenance Guide

This guide provides information about regular maintenance tasks that must be performed on the system.

Conversion Software Guide

This guide provides information about the functions, features, and options available in the conversion software. Also, this guide provides step-by-step instructions about how to convert designs.

Design Creation Guide

This guide provides information and advice on the creation of designs. Also, this guide provides examples for the creation of designs.

Technical Datasheet

This sheet provides information about the system specifications and summarizes the performance and other characteristics of the system. Also, this sheet lists the technical requirements of the system.

2 Safety information

⚠ **Read the safety instructions.** To reduce the risk of severe injury to yourself and others, read and understand the safety instructions before working with or on the system.

Make sure that everyone reads the safety instructions before working with or on the system. Also, consider the risks that may be present resulting from individual conditions.

At all times, follow all warnings and instructions given in the documentation, software interfaces, safety labels on the system, or by our engineers.

2.1 Intended use

Heidelberg Instruments Mikrotechnik products are lithography systems for micro- and nanofabrication. The product is intended for exposing structures on substrates coated with photosensitive materials.

⚠ Heidelberg Instruments Mikrotechnik products are intended only for professional use.

⚠ Operate the product only with the approved materials.

⚠ Operate the product only with flawless substrates free of cracks or scratches. Substrates must comply with the specifications stated in the system specifications and technical data.

⚠ Do not operate the product with flammable substrates, flammable photosensitive materials, or other flammable materials.

⚠ Do not operate the product in a potentially flammable, explosive, or aggressive atmosphere.

⚠ The product is suitable only for indoor use. Comply with the environmental requirements stated in the system specifications and technical data.

⚠ Use only supplementary components, peripherals, accessories, or replacement parts approved by Heidelberg Instruments Mikrotechnik GmbH.

⚠ Changes to factory settings may be carried out only by trained and authorized Heidelberg Instruments Mikrotechnik personnel or by persons explicitly authorized by Heidelberg Instruments Mikrotechnik personnel.

⚠ All product components must always remain within their permitted operating ranges and their installation requirements.

Any use of the product other than that described in the *Intended use* section or explicitly stated in the signed purchase contract does not qualify as the intended use and is to be considered improper and therefore dangerous. Heidelberg Instruments Mikrotechnik GmbH does not assume liability for accidents or damage caused by improper use.

The enclosed documentation is an integral part of the product, and the user is under the obligation to read and understand the documentation before using the product.

The system may only be used for its intended purpose, and only if the system is in faultless condition, safety precautions are taken into account, and the instructions in the user manuals are followed. Issues that may affect safety must be attended immediately. The system may not be used during this time.

Qualified personnel are persons who by reason of their training, experience, instruction and their knowledge of the relevant standards, regulations, accident prevention rules, and working conditions have been authorized by the person responsible for the safety of the machine or facility to perform the appropriate activities required, and thereby are able to recognize and prevent potentially dangerous situations. Knowledge of first aid and the local rescue organization must also be included.

Authorized personnel are persons who can be expected to perform their work reliably. People whose capacity for reaction is influenced, for example, by alcohol, drugs, or medication are not authorized.

When selecting personnel, follow all age- and job-related guidelines applicable to the place of operation.

2.2 Safety first

⚠ Refer to the safety information for personal safety. The safety information contains information about potential hazards (health, physical, and environmental) of the system. For more information, see the Safety Guide.

2.2.1 ELECTRICAL SAFETY

⚠ DANGER

Electrical shock hazard.

Touching live electrical parts can cause serious injury or death.

Do not open housings or covers unless instructed to do so in this manual or by an authorized HIMT engineer.

Do not defeat interlocks, remove connectors, disconnect equipment, nor dismantle or modify equipment.

Do not use the product if cables, plugs, or any other electrical equipment relevant for operation may be damaged or malfunction.

Do not use the product if covers are open. Keep away from energized parts or cables. Do not allow conductive materials to come in contact with energized parts or cables.



⚠ **Do not open covers or modify equipment.** Do not defeat interlocks, remove connectors, disconnect equipment, open safety covers, dismantle or modify equipment. Work on electrical installations may be carried out by trained and authorized HIMT engineers only.

⚠ **Protect cables from mechanical damage.** Damaged cables must be replaced by authorized HIMT engineers only.

⚠ **Protect electrical equipment from moisture, water, and dust.** Do not allow water or any other foreign objects to come in contact with the system's electrical components. Act carefully and take safety precautions if you work with liquids in the vicinity of electrical equipment.

⚠ **Follow local and national electrical regulations and procedures.** Observe the relevant regulations for the prevention of accidents, other occupational health and safety regulations, and the safety regulations of your company for operation of electrical installations and electrical equipment.

2.2.2 LASER SAFETY

⚠ WARNING

Laser radiation class 4

Laser radiation class 4 accessible when covers are open and the interlock is defeated.

Avoid eye or skin exposure to direct or scattered radiation. Laser protection eyewear required.

⚠ CAUTION

Laser radiation class 2

The interferometer laser remains on in standby mode. Laser radiation class 2 is accessible when the loading window is open.

Avoid eye exposure to direct radiation. Do not stare into the beam or view directly with optical instruments.

During operation only the laser radiation of the interferometer laser may be accessible when all covers are closed and the interlock is active. The laser beam of the interferometer system is accessible between the stage mirror and the detector head of the interferometer when the loading window is open.

HIMT does not assume liability for accidents or damage caused by incorrect laser safety measures during operation.



All lasers are classified in accordance with IEC 60825-1:2014.

⚠ Do not open safety covers. The system is designed to protect you from dangerous voltages, laser radiation, and moving parts. All live electrical parts, laser devices, and moving parts are enclosed.

⚠ Do not stare into the interferometer laser beam. Laser protection eyewear is usually not required. Be aware of beam reflections off substrates, glass, or other reflective materials. The laser radiation class 2 of the interferometer system is not a skin of materials burn hazard.

⚠ Operate the product only with flawless substrates free of cracks or scratches. Damaged substrates may cause potentially hazardous beam reflections.

⚠ Do not operate the system with a damaged loading window. If the loading window is damaged, potentially hazardous beam reflections may emerge.

⚠ Laser radiation class 3B and class 4 can cause fire. Do not operate the product with flammable substrates, flammable photosensitive materials, or other flammable materials.

⚠ Caution should be exercised when handling lasers. Lasers are electrical devices and should be treated with the same caution as any other electrical equipment.

For more information about safety measures, see the Safety Guide.

2.2.3 MAGNETIC RESONANCE SAFETY

⚠ WARNING

Risk of interference with implants.

Electric, magnetic, and electromagnetic fields can influence medical implants and impair their functions. Medical implants such as cardiac pacemakers, implanted defibrillators, neurostimulators, or insulin pumps may be at risk in the close vicinity of the machine.

If you wear implants, keep a distance of at least 0.3 meters (12 inches) from the machine. A person-specific evaluation of the interference is recommended.



The following table provides information about the magnetic fields:

Position	Field strength
Magnetic latching of the loading window	144.2 mT (1442 G)
Magnetic snap mechanism at the stage	27.3 mT (273 G)
Write head above the stage	10.9 mT (109 G)
Stepper rotation module	1.6 mT (16 G)

Tab. 3: Magnetic fields

2.2.4 OCCUPATIONAL SAFETY

⚠ DANGER

Risk of serious injury or death.

Live electrical parts, laser radiation, or heat sources may be accessible when safety covers are removed.

Do not open housings or covers unless instructed to do so in this manual or by an authorized HIMT engineer.

Do not use the product if covers are open. Keep away from the system if covers are open.

⚠ CAUTION

Pinch point and shearing hazard.

Injury could result if clothing or body parts become caught in moving mechanisms.

Keep clothing and body parts away from moving mechanisms.

The system is manufactured according to the current state of the art and recognized safety standards. To minimize the remaining risks which cannot be avoided, the system may only be used for its intended purpose, and only if the system is in faultless condition and safety precautions are considered.

HIMT does not assume liability for accidents or damage caused by improper use or incorrect safety measures during operation.



⚠ Moving mechanisms can be dangerous. Keep clothing, hands, and body out of the operating area. Do not stand or sit on any part of the machine.

⚠ Trip and bump hazards are dangerous. Keep cables out of any walkways. Avoid placing objects in walkways.

⚠ When working for extended periods of time, take occasional breaks. Repetitive motion or uncomfortable working environments can lead to injuries over time. Ensure proper posture and ergonomics when working at the system for extended periods of time.

⚠ Wear appropriate personal protective equipment for the job to be performed. Personal protective equipment is usually not required for the operation of the machine. Cleanroom garments are recommended. Observe the health and safety regulations of your company.

2.3 Safety devices

2.3.1 INTERLOCK

To protect the operator from hazards by laser light or stage movement, interlock circuits prevent stage movement and access to laser light while the window is open. During movement and while the system is in processing mode, the window cannot be opened. Opening the window at any other time stops the laser emission and prevents any stage movement.

The interlock can be overridden only by a service engineer. In this state, the system must be considered unsafe.

The safety measures described in the Safety Guide and the Maintenance Guide for servicing periods must be followed.

For the functional safety plan, see the digital data on the USB flash drive that is included in the scope of delivery.

2.3.2 EMERGENCY SWITCHES

⚠ WARNING

Emergency switches must be within reach of an operator.

Emergency switches must be readily accessible to end or avert hazardous situations immediately.

If the distance between the operator's workspace and the closest emergency switch is more than 3 meters, make sure to install additional emergency switches in the vicinity of the operator's workspace. Emergency switches must be located at a height of more than 0.6 m above ground.

To request additional emergency switches, contact the HIMT Service.

NOTICE

Emergency shut-off can damage the system.

The emergency shut-off can cause damage to electrical circuits and other critical components because power is interrupted without an orderly shutdown.

Use the emergency shut-off only in the event of emergency or danger. To turn off the machine normally, put the machine to standby mode. For maintenance and servicing, orderly shut down the system and properly turn off the power.

Only in the event of emergency or danger, press the emergency shut-off switch to stop operation and shut off the machine.

The emergency shut-off switch (EMO) is located at the front of the machine.

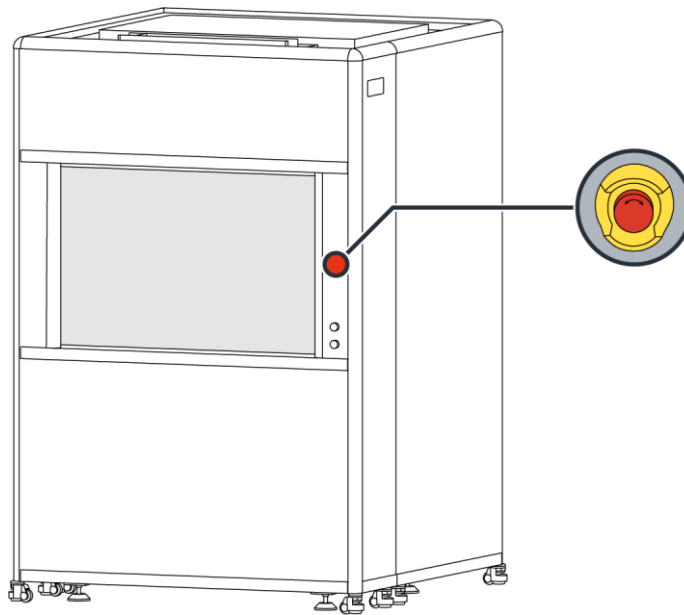

Fig. 2: Emergency shut-off switch

Next to the emergency shut-off switch, you see the label *Emergency Shut-Off Switch*.



Fig. 3: Emergency shut-off safety label

By pressing the emergency shut-off switch, the machine is completely shut off. Only the internal 24 V power supply of the emergency shut-off rack remains on so that the system can be switched on again. Temperature stability is no longer ensured because the temperature regulation is stopped.

After activating an emergency shut-off, the machine remains stopped. The emergency shut-off switch is blocked so that accidentally powering up the machine is not possible. To release the emergency shut-off switch, turn the emergency shut-off switch in the direction that is indicated on the switch.

For information about how to restart the machine after an emergency shut-off, see "5.3.1 Restart the system after emergency shut-off", page 76.

2.4 Disposal

Observe all country-specific waste disposal rules and regulations.

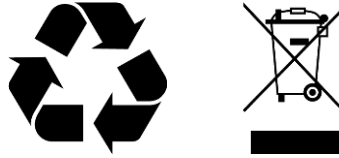

Take all accessories and packaging to an approved disposal site for environmental-friendly recycling. Contact your local HIMT Service Center for the latest information on waste disposal.

Potentially harmful fluids should be disposed of according to local regulations. Always use leakproof containers when you drain fluids. Do not pour waste onto the ground, down a drain, or into any source of water.

3 System

NOTE

This section may contain information about features, options, or objects that are not available for your system.

For information about your system specification, see the Technical Datasheet.

The system consists of the following system components:

- the main unit, which consists of the base, stage, and optics system
- the environmental chamber, which ensures a temperature stable environment inside the housing of the machine
- the electronics and machine control in the electronics cabinet
- the external chiller for the environmental chamber

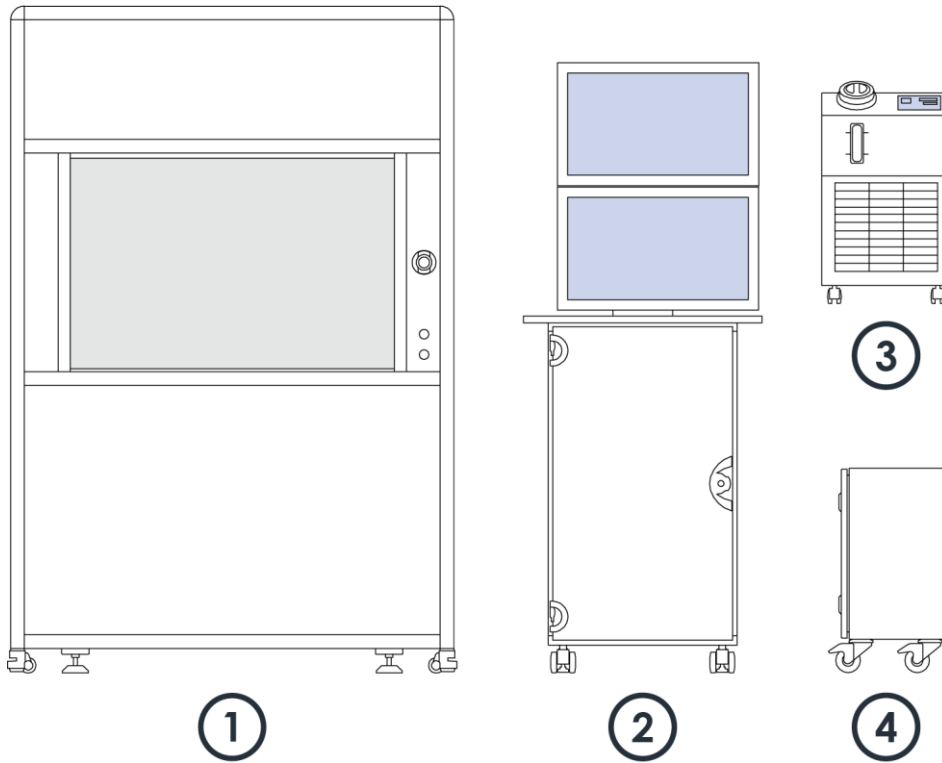

Fig. 4: System components

- | | | | |
|---|--------------------------------------|---|--|
| 1 | Machine | 3 | External chiller for the environmental chamber |
| 2 | Electronics cabinet with workstation | 4 | Step-up transformer (optional) |

3.1 Front

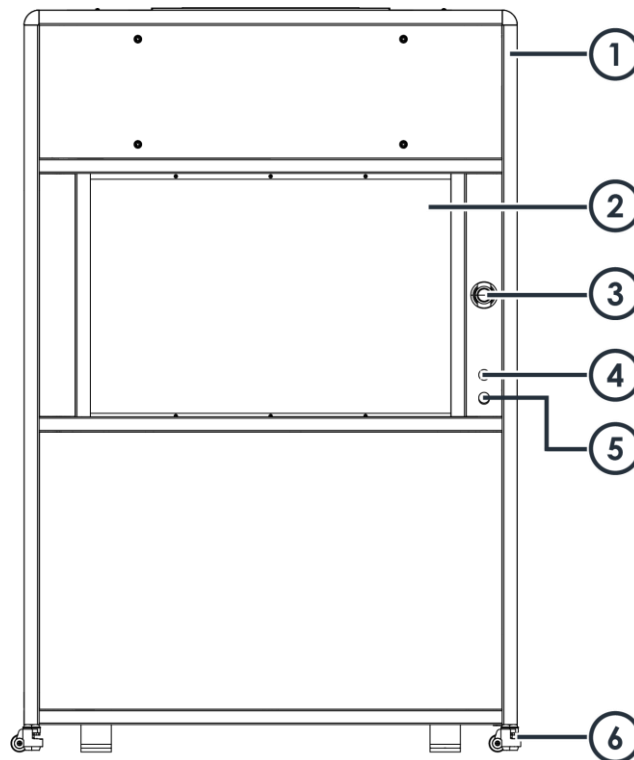

Fig. 5: Front of the machine

- | | | | |
|---|---------------------------------|---|------------------------|
| 1 | Housing | 4 | Light button |
| 2 | Loading window | 5 | Window button |
| 3 | Emergency shut-off switch (EMO) | 6 | Height-adjustable feet |

At the front of the machine, you find the loading window with the **Light** button and the **Window** button. The **Light** button controls the LED in the environmental chamber. The window opens or closes when you press the **Window** button. The window is locked while the stage moves or exposure is in progress. Also at the front, you find the emergency switch.

3.2 Right

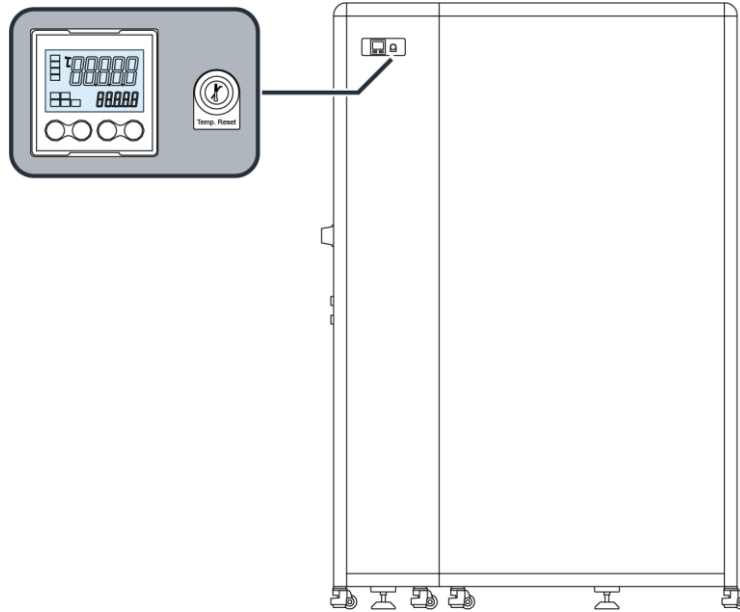

Fig. 6: Right side of the machine

You find the temperature controller in the upper-left corner at the right side of the machine.

TEMPERATURE CONTROLLER

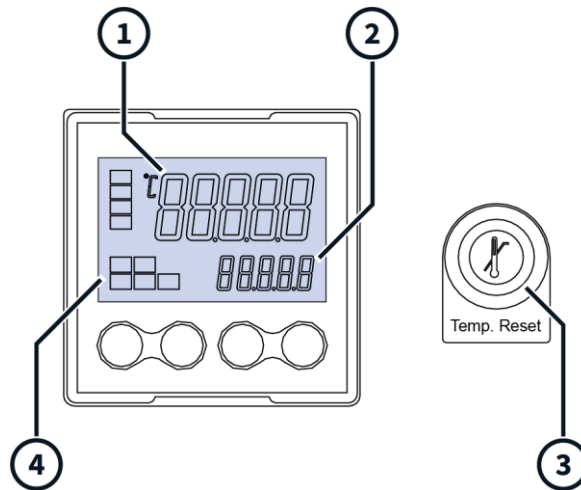

Fig. 7: Temperature controller

- | | |
|----------------------|------------------------------------|
| 1 Actual temperature | 3 Temperature Reset button |
| 2 Target temperature | 4 Heat Output Regulator LED |

At the temperature controller, you find a display that shows the target temperature and the actual temperature of the environmental chamber.

The acceptable deviation between target temperature and actual temperature in the environmental chamber is ± 0.1 °C.

The acceptable deviation between cleanroom temperature and environmental chamber temperature in the environmental chamber is ± 1 °C.

The **Heat Output Regulator** LED indicates the status of the heating circuit. The heating circuit is stable when the **Heat Output Regulator** LED is blinking. If the **Heat Output Regulator** LED is off, the temperature in the environmental chamber is too high.

To regulate the temperature of the environmental chamber, use the temperature controls below the temperature controller display.

If you want to reset the temperature controller after a disturbance is removed, use the **Temperature Reset** button.

3.3 Interior

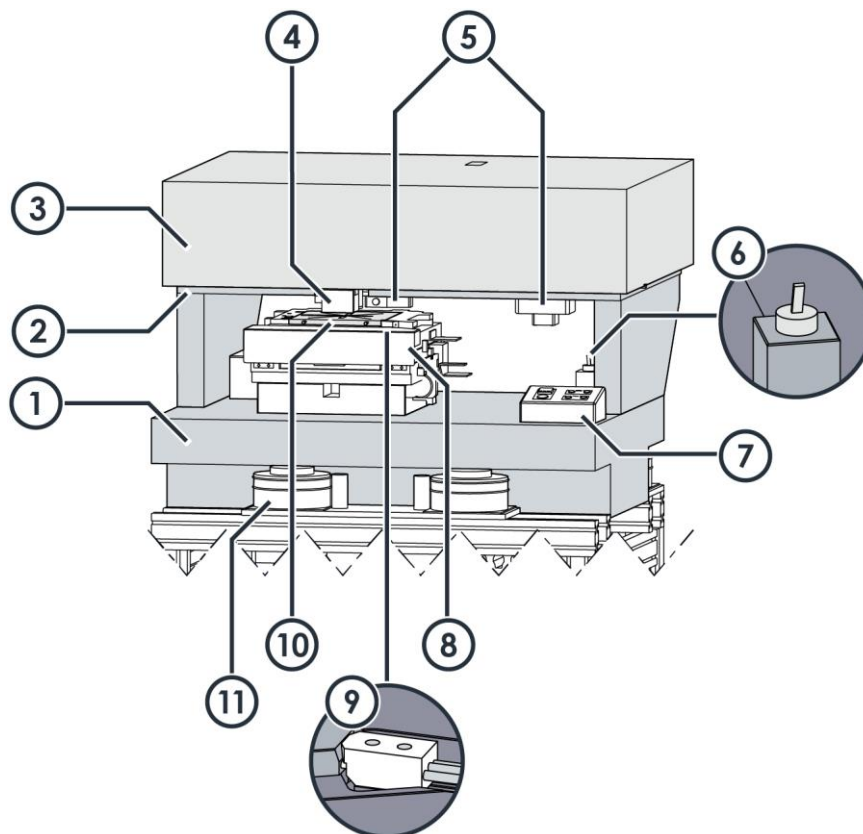

Fig. 8: Interior of the machine

- | | | | |
|---|------------------------|----|------------------------------------|
| 1 | Main unit plate | 7 | Operator panel |
| 2 | Optics mounting base | 8 | Stage system |
| 3 | Exposure optics | 9 | Pneumatic clamp for chuck exchange |
| 4 | Write head | 10 | Exchangeable chuck |
| 5 | Interferometer system | 11 | Vibration isolation system |
| 6 | Pneumatic clamp switch | | |

Inside the machine housing with the environmental chamber, you find the main unit.

The main unit consists of the following components:

- Base system
- Stage system
- Optics system

3.3.1 BASE SYSTEM

The base system consists of the main unit plate, which is mounted on a vibration isolation system. The main unit plate is precision polished to provide uniform properties for the stage. Damages to these surfaces may degrade the patterning quality.

The high mass of the main unit plate ensures effective damping properties in combination with the vibration isolation system. The vibration isolation system is mounted on a heavy-duty aluminum framework, which is designed to minimize bending loads on the main unit plate. To prevent stresses and mechanical distortions of the main unit, the side supports and optics mounting base are all made from the same material as the main unit plate.

The large mass of the base system results in a long thermal time constant, which requires a long equilibration time before the system can produce accurate exposures. The machine must remain at least 1 to 2 days in the final environment with the temperature controller running, either in operational mode or in standby mode, before the final calibration can be completed. To save time during the machine initial setup, standard function tests are usually executed while the system equilibrates thermally.

NOTE

Extreme or changing temperature or humidity can have a negative effect on the stability and accuracy of the exposures.

Keep the temperature of the external environment within 1 °C / 24 h and the humidity stable to ensure the stability of the machine.

The system needs to re-equilibrate if the environmental temperature or humidity changed significantly or if the system was not powered on or monitored for an extended period.

OPERATOR PANEL

The operator panel is located on the main unit plate.

On the operator panel, you find the **Push** button that you use to switch on the vacuum that holds the substrate in place. You can check the vacuum status at the display above the **Push** button.

The LEDs on the right of the operator panel provide status information about the exposure lasers:

- The yellow **On** LED shows if the related exposure laser is switched on or off.
- The red **Emission** LED shows if the related exposure laser is active and exposure is currently in progress.

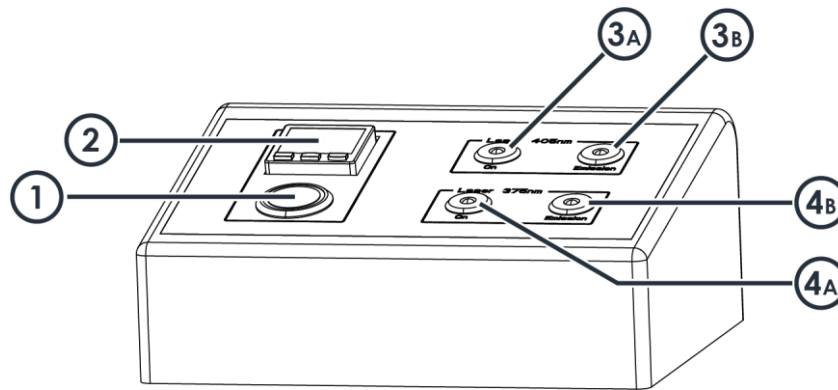

Fig. 9: Operator panel

- | | |
|---------------------------------------|---|
| 1 Push button | 3B Emission status LED, 405 nm laser |
| 2 Vacuum status display | 4A On status LED, 375 nm laser |
| 3A On status LED, 405 nm laser | 4B Emission status LED, 375 nm laser |

3.3.2 STAGE SYSTEM

The stage is mounted on the main unit plate. Linear motors move the stage along the x-axis and the y-axis. The stage moves on air bearings and roller bearings to ensure smooth movement with low positioning errors. One air bearing and one roller bearing support the movement in y-direction. The x-axis is equipped with two roller bearings.

The stage position is monitored online by the interferometer. The system uses the interferometer data to position the stage and to synchronize the exposure light modulation with the location on the exposed substrate.

The system uses an industry-standard, high-resolution interferometer system with proven qualifications for online position control. The interferometer system ensures long-term positioning precision, which is required for high-quality micro-structuring.

The stage is equipped with a chuck. The chuck has vacuum openings to create a vacuum that holds the substrate in place tightly.

The chuck is fixed by a pneumatic clamp. The chuck is exchangeable on demand to meet the requirements of your application.

On the main unit plate, you find the pneumatic clamp switch for opening the pneumatic clamp that holds the chuck. When the pneumatic clamp is open, you can exchange the chuck. For more information, see "7.3 Exchange chucks", page 87.

The stage coordinate system is rotated by 90° clockwise (+90°). On the stage, the x-axis directs from the back to the front and the y-axis directs from the left to the right.



Fig. 10: Stage coordinate system

The rotation is relevant when you load substrates. Also, the rotation is relevant when you navigate via the camera image in the control software. In the camera image, the x-axis directs from the left to the right and the y-axis directs from the bottom to the top.

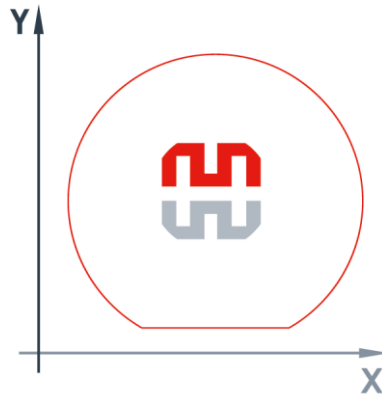

Fig. 11: Camera coordinate system

3.3.3 OPTICS SYSTEM

NOTE

This section may contain information about features, options, or objects that are not available for your system.

For information about your system specification, see the Technical Datasheet.

The optics system consists of the following components:

- Exposure optics
- Camera system
- Write head
- Interferometer system

EXPOSURE OPTICS

The exposure optics are located in a closed housing. The exposure optics housing is mounted on the optics mounting base.

The exposure optics contains the following elements:

- Exposure laser

The high-power exposure diode laser is characterized by high reliability, a long lifetime, and a low noise level. The laser light is emitted by the laser diodes, coupled in optical fiber, and projected on the Digital Mirror Device.
- Digital Micromirror Device (DMD)

The DMD is an electrical input and optical output micro-electric-mechanical system for spatial light modulation. The DMD modulates the write beam so that the laser light projects and transfers a light pattern onto the positive or negative resist on the substrate surface.

- Optical elements

Several optical elements guide the modulated write beam through the optics system before the write beam passes the write head and is projected onto the substrate.

CAMERAS

The camera system contains the following elements:

- Micro camera
- Overview camera

With the micro camera, you can inspect the substrate, perform layer alignments, and carry out high-precision measuring processes.

The micro camera supports the following camera modes:

- High-Resolution Camera mode
- Low-Resolution Camera mode

The High-Resolution Camera mode shows more detail than the Low-Resolution Camera mode, but it covers a smaller area. You use the High-Resolution Camera mode and the Low-Resolution mode to measure alignment marks.

The field of view of the micro camera depends on the camera mode and the write mode.

The overview camera shows less detail than the micro camera, but it covers a much larger area. You use the overview camera to find alignment marks on the substrate. Note that the overview camera possibly does not cover the entire substrate area because of technical limitations.

You control the cameras by using the control software.

WRITE HEAD

The write head is mounted at the bottom of the exposure optics housing.

The write head contains the following elements:

- Stepper motor

The stepper motor moves the write head and enables the write head position to be adjusted to different substrate thicknesses.

- Write lens

The write lens is the last optical element in the exposure beam path before the beam leaves the optics system.

- Pneumatic autofocus

The pneumatic autofocus keeps the focal point of the write beam stable on the surface of the substrate. For probing the distance, compressed air passes through the write head. Then, pressure builds up between the write head and the substrate. The pressure is monitored by a pressure sensor.

- Optical autofocus

The optical autofocus controls the position of the write lens with high precision. The optical autofocus is intended for applications that require high resolution.

INTERFEROMETER SYSTEM

The stage position is monitored online by the interferometer. The system uses the interferometer data to position the stage and to synchronize the exposure light modulation with the location on the exposed substrate.

The system uses an industry-standard, high-resolution interferometer system with proven qualifications for online position control. The interferometer system ensures long-term positioning precision, which is required for high-quality micro-structuring.

3.3.4 BACKSIDE ALIGNMENT SYSTEM

NOTE

This section may contain information about features, options, or objects that are not available for your system.

For information about your system specification, see the Technical Datasheet.

The backside alignment system consists of a micro camera underneath the stage, an overview camera underneath the stage, and a specially designed chuck. The viewing area of the backside alignment cameras cover the lower surface of the substrate.

If your system supports backside alignment, you can expose alignment marks on the lower surface of the substrate instead of the upper surface, which is the exposure side. Backside alignment can provide images with more contrast in cases where layers of resist or other materials on the upper surface might impact the detection of the alignment marks.

On the first layer, you expose only the alignment marks. For the exposure of all further layers, you turn the substrate so that the exposed alignment marks are at the lower surface. Then, you can use the backside camera underneath the stage to find and center the alignment marks.

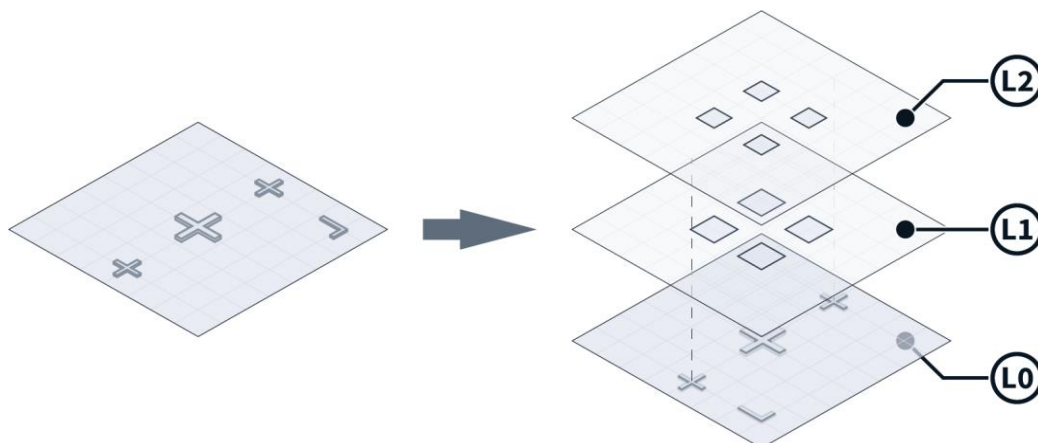

Fig. 12: Backside alignment marks on the lower surface

When you perform a backside alignment, note that coordinates always refer to the substrate side that is currently the upper surface. So, an alignment mark that is exposed on the right side will be on the left side when you turn around the substrate. This means, if an alignment mark is exposed at position $[X: +20\text{ mm}]$, the alignment mark will be at position $[X: -20\text{ mm}]$ for the backside alignment.

The chuck for backside alignment has designated openings through which the backside camera can detect alignment marks on the lower surface of the substrate. The

alignment marks on the lower surface must be within the area of the openings for the backside camera to be able to detect the alignment marks.

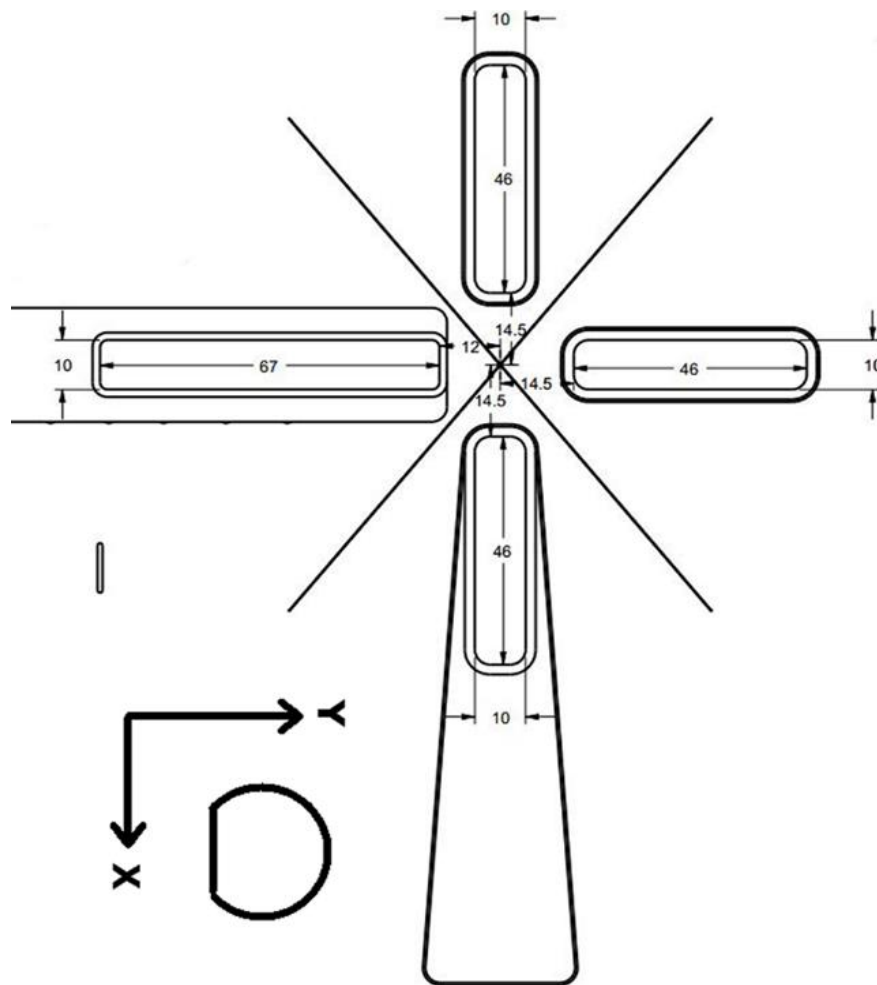

Fig. 13: Chuck – Backside alignment zones (standard chuck layout)

The alignment marks can be positioned anywhere within the backside alignment zones. For easy handling and best resolution, positioning the alignment marks on the center axes of the chuck is recommended.

Based on experience, alignment marks with a cross size of 300 μm \times 300 μm and a line width of 20 μm may give good results.

The following table shows proposals for the positioning of alignment marks:

Wafer size	Mark 1	Mark 2	Mark 3	Mark 4
2 inch	X: +20 mm Y: 0	X: -20 mm Y: 0	X: 0 Y: +20 mm	X: 0 Y: -20 mm
3 inch	X: +28 mm Y: 0	X: -28 mm Y: 0	X: 0 Y: +28 mm	X: 0 Y: -28 mm
4 inch	X: +40 mm Y: 0	X: -40 mm Y: 0	X: 0 Y: +40 mm	X: 0 Y: -40 mm
5 inch	X: +44 mm Y: 0	X: -44 mm Y: 0	X: 0 Y: +44 mm	X: 0 Y: -44 mm

Tab. 4: Backside alignment – Alignment mark positions – Examples

3.4 Environmental chamber

The environmental chamber ensures constant exposure conditions. The environmental chamber provides temperature stable conditions for the base system, the stage system, and the optics system. A laminar air flow maintains particulate-free air by using an integrated filter system.

The environmental chamber is equipped with a safe light for illumination. The safe light can be useful during the loading or unloading procedure. To avoid flawed results, do not expose substrates to the safe light for prolonged periods and make sure to switch off the safe light during the exposure procedure.

For more information, see the Technical Datasheet.

CHILLER

The chiller for the environmental chamber is a water-cooling system, which ensures a stable target temperature inside the environmental chamber.

Maintaining a constant temperature throughout the environmental chamber is essential to consistently produce high-quality and accurate exposure results.

NOTICE

Risk of malfunction.

If the coolant level is below the minimum level, the function of the chiller cannot be guaranteed.

Check the coolant level regularly. If the coolant level is at or below the minimum mark, inform the administrator, the maintenance staff, or the Heidelberg Instruments Mikrotechnik Customer Service.

For more information, see the Maintenance Guide.

The chiller for the environmental chamber is a separate device.

3.5 Electronics cabinet

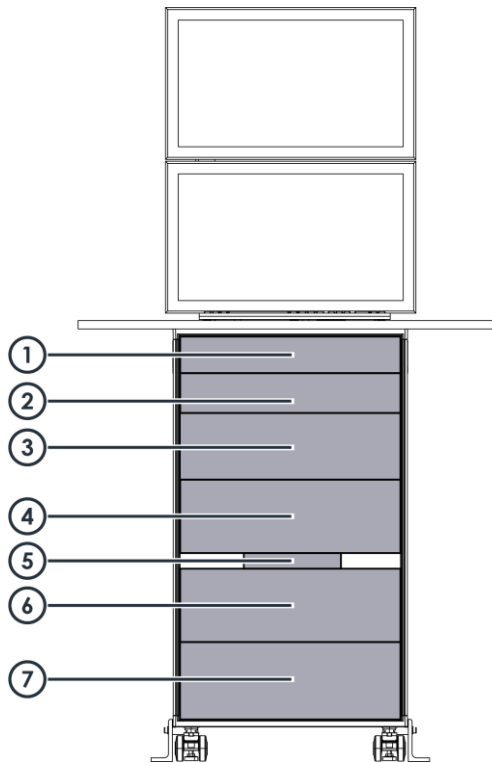

Fig. 14: Electronics cabinet (exemplary picture)

- | | | | |
|---|------------------------|---|--|
| 1 | Conversion PC | 5 | System network switch |
| 2 | User PC | 6 | Stage controller rack |
| 3 | Power supply rack | 7 | Integrated chiller for the laser and the stage |
| 4 | Autofocus control rack | | |

3.6 Step-up transformer

NOTE

This section may contain information about features, options, or objects that are relevant only for systems with a transformer. If your system is not equipped with a transformer, skip the information that is related to the transformer.

For information about your system specification, see the Technical Datasheet.

The step-up transformer increases the voltage level of the incoming power supply.

The step-up transformer is needed only if the power supply of the facility does not provide the permissible supply voltages for the system.

3.7 Electronics

You find the electronics in the electronics cabinet. The electronics cabinet is located below the workstation, which is usually installed near the machine.

3.7.1 SYSTEM NETWORK SWITCH

The components of the system communicate via a dedicated, internal LAN (local area network). To enable communication between the components, all components are connected to the system network switch. To enable communication with the external facility network, all PCs delivered with the system support dual networking.

NOTICE

Risk of malfunction and delay

If you connect components that are not part of the system to the system network switch or if you connect the system network switch directly to the facility network, data processing and command transfer can be disturbed, which can result in malfunction or delay.

Do not connect any non-system components to the system network switch.

Do not connect the system network switch to the facility network.

3.7.2 AUTOFOCUS CONTROL RACK

The autofocus control rack controls the autofocus system. The autofocus control rack receives sensor data about the distance between the write lens and the substrate. According to the sensor data, the autofocus control rack regulates and stabilizes the focal length in realtime.

The autofocus control rack also controls the motors of the machine. The motors are used in various functions throughout the system, for example, to control the positions of the optical elements to the selected write mode.

3.7.3 POWER SUPPLY RACK

The power supply rack controls the power distribution for all components of the system.

At the front of the power supply rack, you find the main switch. Next to the main switch, you find the system power controls, which are the green **On** button and the red **Off** button.

The power supply rack also controls the function of the emergency switch.

3.7.4 STAGE CONTROLLER RACK

The stage controller receives signals from the interferometer. Based on the received interferometer measurement data, the stage controller coordinates and drives the stage.

In addition, the stage controller generates the trigger signals, which control the Digital Micromirror Device (DMD) and the laser.

3.7.5 CHILLER

The chiller controls the temperature of the laser and the stage.

The chiller is a water-cooling system, which removes waste heat and ensures a stable target temperature of the cooled components.

Maintaining a constant temperature of the components is essential to consistently produce high-quality and accurate exposure results.

The target temperature of the chiller must be identical to the temperature of the environmental chamber.

3.7.6 CONVERSION PC

The conversion PC is running under the Linux operating system. The conversion PC is connected to the user PC.

On the conversion PC, the conversion software is installed. The conversion software converts the design data into machine-readable design data so that the design can be processed by the system.

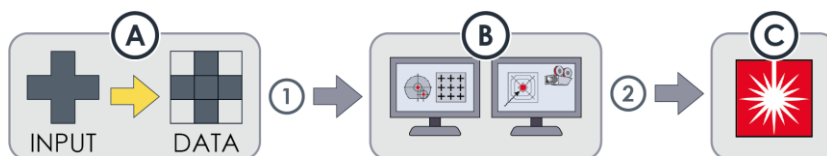

Fig. 15: Conversion of design data and design processing

The conversion software **[A]** converts input files into machine-readable design data. The user PC **[B]** can access and load **[1]** the design data on demand. The design data is stored at the user PC. On the user PC, you can position the design and configure the settings for exposure. When you start the exposure, the user PC sends **[2]** the data to the Digital Micromirror Device (DMD) **[C]**, which executes the exposure.

3.7.7 USER PC

The user PC is running under the Windows operating system. The user PC is connected to the main unit and the conversion PC.

The user PC provides the control software with a graphical user interface. With the control software, you can control and monitor the system. Also, you use the control software to edit, manage, and execute exposure and alignment jobs. For the jobs, you can select the designs provided by the conversion software.

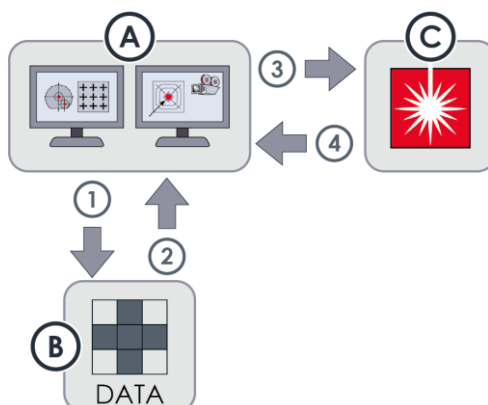

Fig. 16: Control and data processing

When you start an exposure job, the control software **[A]** sends a request **[1/2]** to the conversion software **[B]** to access the converted design data. Then, you can place the converted design in the exposure job and configure the exposure job. Then, you can start the exposure.

After you started the exposure, the control software sends **[3]** the related commands to the main unit **[C]**. The user PC sends the exposure commands stripe by stripe. When a stripe is exposed, the main unit signalizes **[4]** that the stripe is finalized and receives the exposure commands for the next stripe.

3.8 Software

The conversion software and the control software are essential for operating the machine. Other utility software may be preinstalled, such as PDF Reader software.

On the desktop of the user PC, you usually find desktop shortcuts for the conversion software and the control software. You can use the desktop shortcuts as usual to start the software. If the desktop shortcuts are not available, you can use the Start menu to start the software. Also, you can create and manage desktop shortcuts as desired, as on every Windows PC.

3.8.1 CONVERSION SOFTWARE

You use the conversion software to convert image files, such as CAD data or bitmap images, into the machine-specific format so that the design can be processed by the system.

In the conversion software, you can import image files of the supported file formats to compile designs. For the designs, you can already set relevant preprocessing parameters. Finally, you prepare the design for later use by the control software.

The system uses the following conversion software: APP

3.8.2 CONTROL SOFTWARE

You use the control software to control and monitor the system. You can create, edit, manage jobs. You can use the converted design data to set up exposure jobs. Also, you can preconfigure jobs with custom settings for frequently used applications. To start and execute common applications, the control software offers wizards that guide you through the processes step by step.

Administrators use the control software to create presets for shared application objects, to administer users and user access rights, or to check the status of the system devices.

The system uses the following control software: MLA Menu

3.8.3 TEAMVIEWER SOFTWARE

The TeamViewer software is preinstalled. You can use the TeamViewer software to invite a Heidelberg Instruments Mikrotechnik service engineer to attend a remote service session.

You can start the TeamViewer session by double-clicking the desktop shortcut or via the Start menu. When the software is started, navigate to the Remote Control tab of the main interface. There, you find your Team Viewer ID and your temporary password. With this information, you can allow a Heidelberg Instruments Mikrotechnik service engineer remote control.

For more information, see the documentation of the manufacturer.

NOTICE

Do not update the factory-installed TeamViewer software

Updating the TeamViewer software can cause compatibility issues.

Updates should be performed only in consultation with the HIMT Service.

3.8.4 ANYDESK SOFTWARE

The AnyDesk software is preinstalled. You can use the AnyDesk software to invite a Heidelberg Instruments Mikrotechnik service engineer to attend a remote service session.

You can start the AnyDesk session by double-clicking the desktop shortcut or via the Start menu. When the software is started, you find your AnyDesk ID in the AnyDesk window. With this information, you can invite a Heidelberg Instruments Mikrotechnik service engineer to a remote service session.

For more information, see the documentation of the manufacturer.

4 User interface

The MLA Menu implements a graphical user interface, which guides you through the exposure process and provides status information about the system.

4.1 Primary window

The primary window contains general control objects and display objects.

The primary window consists of the following sections:



Fig. 17: Main window

- | | | | |
|---|--|---|-------------------------|
| 1 | Menu bar | 5 | Progress Info frame |
| 2 | Job Process Overview frame | 6 | Hardware Info frame |
| 3 | Exposure Info frame | 7 | Context-dependent frame |
| 4 | Alignment Info frame
(or) Series Info frame | | |

The content of the context-dependent frame varies depending on the selected process step.

4.1.1 MENU BAR

Object	Description
File	
Exit	End your work session and log out.
Tools	
Large Camera Defoc	<p>Activate the extended camera focus offset for exposure and alignment procedures.</p> <p>The regular camera focus offset covers only a limited focus range. By activating the extended camera focus offset, the camera focus offset is extended to cover the complete focus range.</p> <p>Usually, the camera focus offset applies only to the camera. Only if you select a substrate template for which Expose with Camera Focus is activated, the camera focus offset applies also to the exposure. For more information, see "Set up substrate templates", page 145.</p>
Initialize Stage	Initialize the stage
Reboot Stage Controller	Reboot the stage controller.
Initialize Backside Lense	<p>Initialize the backside alignment system.</p> <p>This object is only relevant for systems that support backside alignment.</p>
Initialize Optical AutoFocus	<p>Initialize the optical autofocus.</p> <p>This object is only relevant for system that are equipped with an optical autofocus.</p>
Laser Measurement	<p>Measure the laser power and compare the measured value with the result of the last laser calibration.</p> <p>This function is restricted to users with extended user rights.</p>
Beam Offset	<p>Adjust the beam offset.</p> <p>This function is restricted to users with extended user rights.</p>
Backup	<p>Create a system backup.</p> <p>This function is restricted to users with extended user rights.</p>
Logging (<mode>)	<p>Adjust the settings for monitoring the system activity.</p> <p>This function is restricted to users with extended user rights.</p> <p>Do not change any properties without explicit authorization.</p>
User Management	
Change Users	Log in as another user.
Info	
Exposure History	Show information about the last exposure jobs.
Startup Info	Show information about the system, which was logged during startup.

About	
About	Open a dialog box that shows information about the control software





Tab. 5: Primary window – Menu bar

4.1.2 JOB PROCESS OVERVIEW FRAME

The frame shows a complete overview of the job process with all possible process steps.

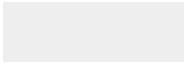

Fig. 18: Job Process Overview frame

Object	Description
	Indicates that the context-dependent frame with the associated process step properties is currently displayed below.
	Indicates that the process step is already executed.
	Indicates that the process step is not yet executed.
	Expand the process step to show the subprocesses.
	Collapse the process step to hide the subprocesses.

Tab. 6: Job Process Overview frame – Control and display objects

4.1.3 EXPOSURE INFO FRAME

The frame shows information about the exposure settings.

Exposure Info			
Job Name	demo	No.	2713
Substrate Size [mm]	100.4	Height	0.50
Design Name	MLA1000	Layer	First Ex
Design Type	Binary	Convert	Prepare
Design Size [mm]	3.0 x 11.0	Mode	Quality
Dose [mJ/cm ²]	80	Defoc	0

Fig. 19: Exposure Info frame

Object	Description
Job Name	Shows the name of the exposure job.
Substrate Size [mm]	Shows the size of the substrate in millimeters.
Design Name	Shows the name of the design.
Design Type	Shows if the design is a binary raster design or a grayscale design.
Design Size [mm]	Shows the height and the width of the design in millimeters.
Dose [mJ/cm²]	Shows the light intensity that is set for the exposure in millijoules per square centimeter.
No.	Shows the system-internal job number. The job number is set automatically by the system and cannot be changed.
Height	Shows the height of the substrate in millimeters.
Layer	Shows the layer that is to be exposed.
Convert	Shows the status of the conversion process.
Mode	Shows the exposure quality that was selected during the conversion process: <ul style="list-style-type: none"> • Quality: Highest quality, longer exposure process duration • Fast: Lower quality, shorter exposure process duration
Defoc	Shows the focus offset that is set for the exposure process. With the focus offset, you precisely adjust the focus position and focal point of the write head. For example, you can adjust the focus position to suit the thickness of the resist. The value is an integer number in the range of -10 to 10.

Tab. 7: Exposure Info frame – Display objects

4.1.4 ALIGNMENT INFO FRAME

The frame shows information about the positions of the alignment marks.

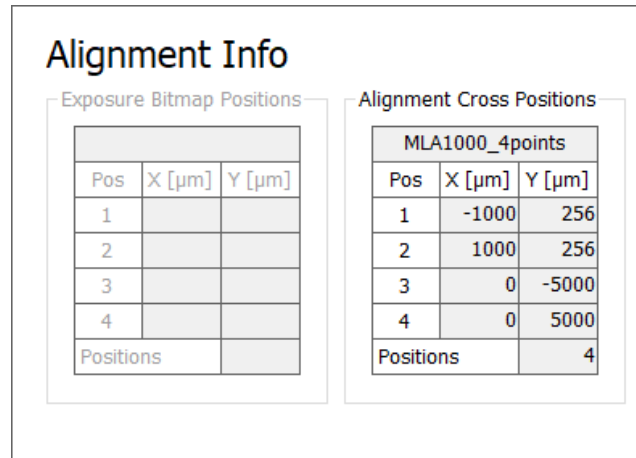

Fig. 20: Alignment Info frame

Area	Description
Exposure Bitmap Positions	Shows the index number, the x-coordinate, and the y-coordinate of the bitmaps, such as alignment marks, that you expose in addition to a selected design. This information is available if you selected a bitmap template for the layer.
Alignment Cross Positions	Shows the index number, the x-coordinate, and the y-coordinate of the alignment marks that are used for alignment. This information is available if you selected an alignment template for the layer.

Tab. 8: Alignment Info frame - Frames

Object	Description
Pos	Shows the index number of the bitmap or alignment mark position.
X [μm]	Shows the x-coordinate of the bitmap or alignment mark position. The position is set in the template.
Y [μm]	Shows the y-coordinate of the bitmap or alignment mark position. The position is set in the template.
Positions	Shows the total number of bitmaps or alignment marks.

Tab. 9: Alignment Info frame – Display objects

4.1.5 SERIES INFO FRAME

The frame shows information about the exposure series settings.

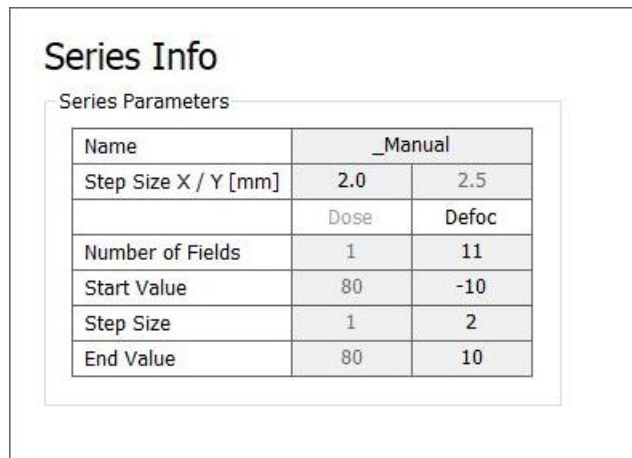

The screenshot shows a window titled "Series Info" containing a "Series Parameters" table. The table has three columns: "Name", "_Manual", and "Dose/Defoc". The rows represent various parameters and their values for the "Dose" and "Defoc" series.

Name	_Manual	
Step Size X / Y [mm]	2.0	2.5
	Dose	Defoc
Number of Fields	1	11
Start Value	80	-10
Step Size	1	2
End Value	80	10

Fig. 21: Series Info frame

Object	Description
Name	Shows the name of the exposure series.
Step Size X / Y [mm]	Shows the distance between the designs that are to be exposed in the exposure series: <ul style="list-style-type: none"> The value in the left column shows the distance that is added between the start of one design and the start of another design on the x-axis. The value in the right column shows the distance that is added between the start of one design and the start of another design on the y-axis.
Dose/Defoc	Shows if the exposure series is a dose series, a focus offset series, or a dose / focus offset matrix.
Number of Fields	Shows the number of designs that are to be exposed in the exposure series.
Start Value	Shows the starting value of the exposure series: <ul style="list-style-type: none"> In the Dose column, the value shows the starting light intensity that is set for the exposure in millijoules per square centimeter. In the Defoc column, the value shows the starting focus offset.
Step Size	Shows the increment per die that is to be exposed in the exposure series.

End Value	<p>Shows the final value of the exposure series:</p> <ul style="list-style-type: none"> In the Dose column, the value shows the final light intensity that is set for the exposure in millijoules per square centimeter. In the Defoc column, the value shows the final focus offset.
------------------	---

Tab. 10: Series Info frame – Display objects

4.1.6 PROGRESS INFO FRAME

The frame shows information about the exposure progress.

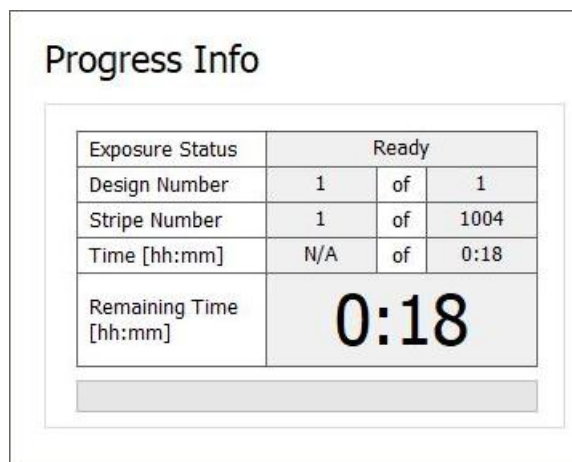

Fig. 22: Progress Info frame

Object	Description
Exposure Status	Shows the status of the exposure job.
Design Number	Shows which design is currently exposed and the total number of designs that are to be exposed.
Stripe Number	Shows which stripe of the design is currently exposed and the total number of stripes in the design.
Time [hh:mm]	Shows the elapsed time and the estimated total time of the exposure process.
Remaining Time [hh:mm]	Shows the estimated remaining time of the exposure process.

Tab. 11: Progress Info frame – Display objects

4.1.7 HARDWARE INFO FRAME

The frame shows information about the system status.

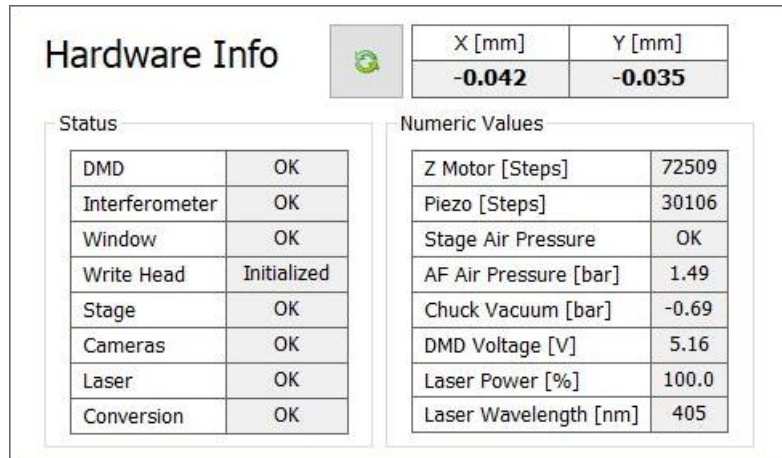



Fig. 23: Hardware Info frame

The header contains general control and display objects.

Object	Description
	Refresh the information in the frame.
X [mm]	Shows the x-coordinate of the current position of the stage in the stage coordinate system.
Y [mm]	Shows the y-coordinate of the current position of the stage in the stage coordinate system.

Tab. 12: Hardware Info frame – Header – Control and display objects

The *Status* frame shows information about the system devices. If errors are shown, click  to refresh the information. If the issue persists, go to **Info » Startup Info** to determine the root cause of the issue.

Object	Description
DMD	Shows the status of the Digital Mirror Device (DMD).
Interferometer	Shows the status of the interferometer.
Window	Shows if the loading window is open or closed.
Write Head	Shows the status of the write head.
Stage	Shows the status of the stage.
Cameras	Shows the status of the cameras.
Laser	Shows the status of the laser.
Conversion	Shows the status of the conversion PC.

Tab. 13: Hardware Info frame – Status frame – Display objects

The *Numeric Values* frame shows detailed information about the system devices.

Object	Description
Z Motor [Steps]	Shows the number of steps that the stepper motor of the write head has performed.
Piezo [Steps]	Shows the number of steps that the write head piezo has performed.
Stage Air Pressure	Shows the status of the air pressure of the stage.
AF Air Pressure [bar]	Shows the air pressure of the autofocus in bar.
Chuck Vacuum [bar]	Shows the air pressure of the chuck vacuum in bar.
DMD Voltage [V]	Shows the voltage of the Digital Mirror Device (DMD) in volts.
Laser Power [%]	Shows the power of the laser as a percentage of the maximum power.
Laser Wavelength [nm]	Shows the wavelength of the currently selected laser in nanometers. If the field shows ---, no laser is selected. This field is only relevant if more than one laser is installed on the system.

Tab. 14: Hardware Info frame – Numeric Values – Display objects

4.1.8 SETUP JOB FRAME

This context-dependent frame shows the settings for the current job. In this frame, you set and check the settings before you start the job.

The frame opens automatically when you start the control software.

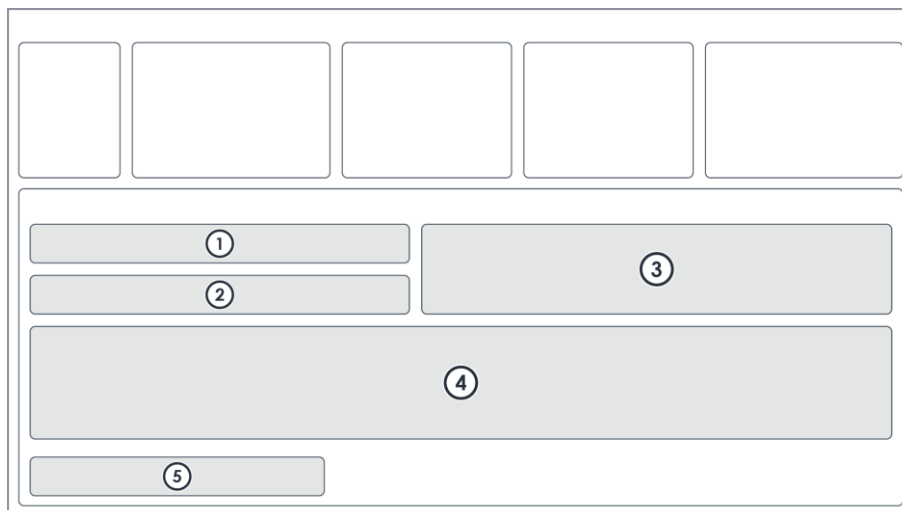

Fig. 24: Setup Job frame



- | | |
|--------------------|---|
| 1 Job | 4 Layer (or) Series (or) Draw Mode |
| 2 Substrate | 5 Proceed |
| 3 Info | |

Area	Description
Job	<p>Set the job name and set the exposure mode.</p> <p>You can choose from the following exposure modes:</p> <ul style="list-style-type: none"> • Standard: Select this option if you want to execute an exposure. Multi-layer exposures are possible. You can expose a single design on each layer. • Series: Select this option if you want to execute a dose series, a focus offset series, or a dose / focus offset matrix. • DrawMode: Select this option if you want to execute an exposure of an ad hoc shape. • Inspection: Select this option if you want to inspect the loaded substrate. <p>Alternatively, you can load a previously saved job. Then, you can modify the settings and execute an exposure.</p>
Substrate	<p>Shows the substrate settings for your application.</p> <p>Double-click the field below Substrate Template to open the <i>Load Substrate</i> frame and select a substrate template.</p>
Info	<p>Shows tips and information about the process step.</p>
Layer	<p>Manage the layers of the exposure and modify the layer settings.</p> <ul style="list-style-type: none"> • Add Layer: Add a row to the <i>Layer</i> table. • Copy Layer: Add a row with the same settings as the selected layer to the <i>Layer</i> table. • Delete Layer: Delete the currently selected row from the <i>Layer</i> table. <p>This frame is only available for the standard exposure mode.</p>
Series	<p>Select the exposure series template and modify the exposure series settings.</p> <p>This frame is only available for the series exposure mode.</p>
Draw Mode	<p>Modify the draw mode settings.</p> <p>This frame is only available for the draw mode exposure mode.</p>

Proceed	<p>Proceed to the next process step:</p> <ul style="list-style-type: none"> • Load Substrate: Open the <i>Load Substrate <name></i> frame and load a substrate. • First Exposure: Open the <i>First Exposure</i> frame and execute the exposure process. This option is only available if the First Exposure layer is selected and if a substrate is already loaded. • Alignment: Open the <i>Alignment</i> frame and execute the alignment of the alignment marks. This option is available if a layer is selected that is not the First Exposure layer and if a substrate is already loaded. • Series: Open the <i>Series</i> frame and execute the exposure series. This option is available only for the series exposure mode and if a substrate is already loaded. • Draw Mode: Open the <i>Draw Mode</i> frame and execute the exposure of an ad hoc shape. This option is available only for the draw mode exposure mode and if a substrate is already loaded. • Inspection: Open the <i>Inspection Mode</i> frame and inspect the loaded substrate. This option is available only for the inspection mode and if a substrate is already loaded. • Unload Substrate: Unload the currently loaded substrate.
---------	--

Tab. 15: Setup Job frame – Control and display elements

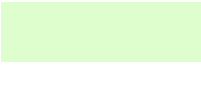
The following table explains the color highlighting in the *Layer* table, the *Series* table, and the *Draw Mode* table:

Color	Description
	Indicates that the value is valid. If the value is optional, the field can be empty.
	Indicates that the value is invalid. You must set a valid value.

Tab. 16: Setup Job frame – Tables – Color highlighting

4.1.9 LOAD SUBSTRATE FRAME

This context-dependent frame shows the available substrate templates. In this frame, you select a substrate template, and you can check, update, and manage substrate templates.

The frame opens when you double-click the field below **Substrate Template** in the *Substrate* frame of the *Setup Job* frame.

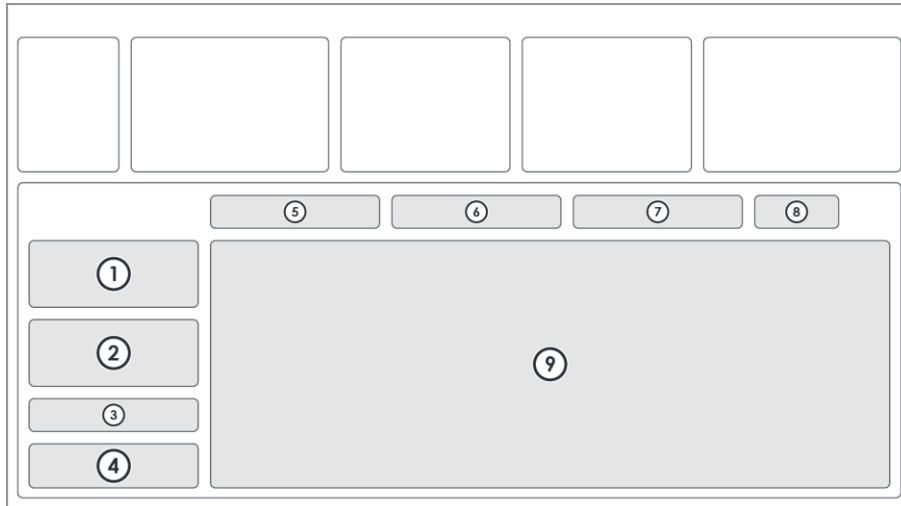

Fig. 25: Load Substrate frame

- | | | | |
|---|---------------------|---|---------------------|
| 1 | Characteristics | 6 | Search |
| 2 | Advanced Parameters | 7 | Show |
| 3 | Edit | 8 | Results |
| 4 | Comment | 9 | Substrate Templates |
| 5 | Load | | |

Area	Description
Characteristics	Shows the parameters of the currently selected substrate template. Only users with extended user rights can edit the parameters.
Advanced Parameters	Shows additional parameters of the currently selected substrate template. Only users with extended user rights can edit the parameters.
Edit	<p>Edit and manage the substrate templates.</p> <ul style="list-style-type: none"> • New: Create a new substrate template. • Copy: Copy the currently selected substrate template. • Edit: Edit the currently selected substrate template. • Save: Save the currently selected substrate template with the current settings. • Delete: Delete the currently selected substrate template. <p>These options are available only for users with extended user rights.</p>
Comment	Shows an optional comment. Only users with extended user rights can set or edit a comment.
Load	<p>Confirm or cancel the selection of the substrate template.</p> <ul style="list-style-type: none"> • Load: Confirm the selection of the substrate template and return to the <i>Setup Job</i> frame. • Cancel: Cancel the selection of the substrate template and return to the <i>Setup Job</i> frame. • Refresh: Refresh the display of the <i>Substrate Templates</i> table below.
Search	Enter a search query to search for substrate templates.

Show	Limit the number of displayed substrate templates or show more substrate templates.
Results	Shows the number of loaded substrate templates.
Substrate Templates	Shows the available substrate templates. If you started a search, the table shows the matching search results. Click an entry to select the corresponding template. Click any column header to sort the entries in the table alphabetically.

Tab. 17: Load Substrate frame – Control and display elements

4.1.10 LOAD SERIES FRAME

This context-dependent frame shows the available series templates. In this frame, you select a series template, and you can check, update, and manage series templates.

The frame opens when you double-click the field below **Series Template** in the *Series* frame of the *Setup Job* frame.

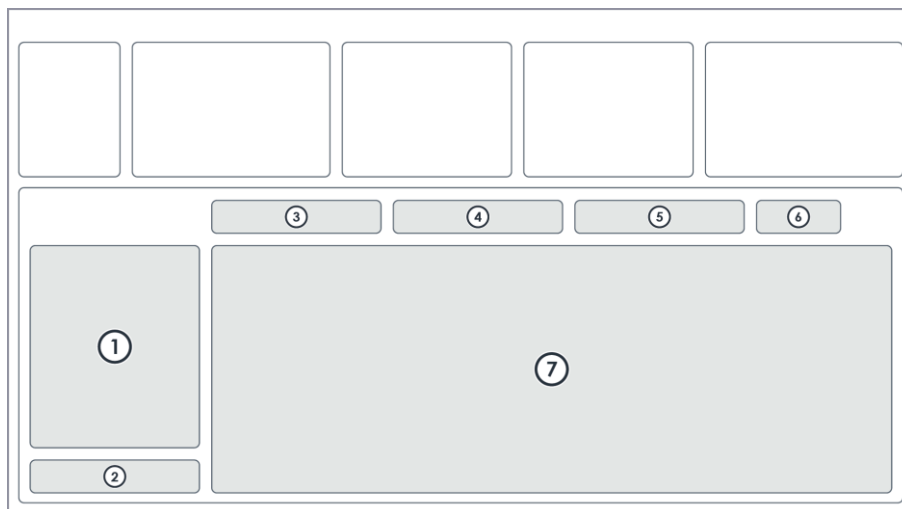

Fig. 26: Load Series frame

- | | |
|--------------|--------------------|
| 1 Parameters | 5 Show |
| 2 Edit | 6 Results |
| 3 Load | 7 Series Templates |
| 4 Search | |

Area	Description
Parameters	Shows the parameters of the currently selected series template.
Edit	Edit and manage the series templates. <ul style="list-style-type: none"> • New: Create a new series template. • Copy: Copy the currently selected series template. • Edit: Edit the currently selected series template. • Save: Save the currently selected series template with the current settings. • Delete: Delete the currently selected series template.

Load	<p>Confirm or cancel the selection of the series template.</p> <ul style="list-style-type: none"> • Load: Confirm the selection of the series template and return to the <i>Setup Job</i> frame. • Cancel: Cancel the selection of the series template and return to the <i>Setup Job</i> frame. • Refresh: Refresh the display of the <i>Series Templates</i> table below.
Search	Enter a search query to search for series templates.
Show	Limit the number of displayed series templates or show more series templates.
Results	Shows the number of loaded series templates.
Series Templates	<p>Shows the available series templates.</p> <p>If you started a search, the table shows the matching search results. Click an entry to select the corresponding template.</p> <p>Click any column header to sort the entries in the table alphabetically.</p>

Tab. 18: Load Series frame – Control and display elements

4.1.11 LOAD DESIGN FRAME

This context-dependent frame shows the available designs on your local file system. In this frame, you can select a design and you can check, update, and manage designs. Also, you can open the conversion software to add and edit designs.

The frame opens when you double-click the field below **Design** in the *Layer* frame or *Series* frame of the *Setup Job* frame.

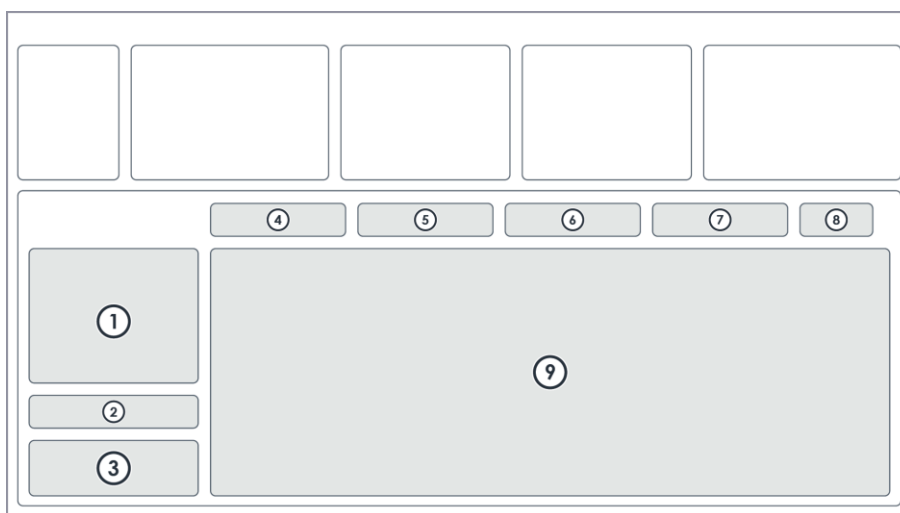

Fig. 27: Load Design frame

- | | | | |
|---|-----------------|---|---------|
| 1 | Characteristics | 6 | Search |
| 2 | Edit | 7 | Show |
| 3 | Comment | 8 | Results |
| 4 | Prepare | 9 | Designs |
| 5 | Load | | |

Area	Description
Parameters	Shows the parameters of the currently selected designs.
Edit	Edit and manage the designs. <ul style="list-style-type: none"> • Complete Designs: Complete the conversion of <i>online</i>-converted designs (<i>prepared</i>). After completion, the designs are <i>offline</i>-converted (<i>completed</i>). • Delete Designs: Delete the currently selected designs.
Prepare	Click Convert Design to open the conversion software. In the conversion software, you can create designs or modify existing designs. Then, you can convert the designs to make the designs available in the control software.
Load	Confirm or cancel the selection of the designs. <ul style="list-style-type: none"> • Load: Confirm the selection of the designs and return to the <i>Setup Job</i> frame. • Cancel: Cancel the selection of the designs and return to the <i>Setup Job</i> frame. • Refresh: Refresh the display of the <i>Design</i> table below. It is recommended to click refresh after you made design changes in the conversion software, including design creation, design modification, and other changes. This way, you ensure that the data of the conversion software and the control software are synchronized.
Search	Enter a search query to search for designs.
Show	Limit the number of displayed designs or show more designs.
Results	Shows the number of loaded designs. If the shown numbers deviate, the control software did not accept all designs that exist in the conversion software. For example, if you see 12/15 or similar, the control software accepted only the 12 new designs but there are 3 more designs, which are outdated. You can load the outdated designs by loading the designs in the conversion software and converting the designs again. Then, the designs are up to date and the control software accepts the missing designs.
Designs	Shows the available designs. If you started a search, the table shows the matching search results. Click an entry to select the corresponding design. If you want to select multiple designs, hold the Ctrl key and click the entries. Click any column header to sort the entries in the table alphabetically.

Tab. 19: Load Designs frame – Control and display elements

4.1.12 LOAD EXPOSURE BITMAPS FRAME

This context-dependent frame shows the available bitmap templates. Bitmap templates contain information about bitmaps, such as alignment marks or other image information, that you expose in addition to a selected design during the exposure of the layer. In this frame, you select a bitmap template, and you can check, update, and manage bitmap templates.

The frame opens when you double-click the field below **Exposure Bitmaps** in the *Layer* frame of the *Setup Job* frame.

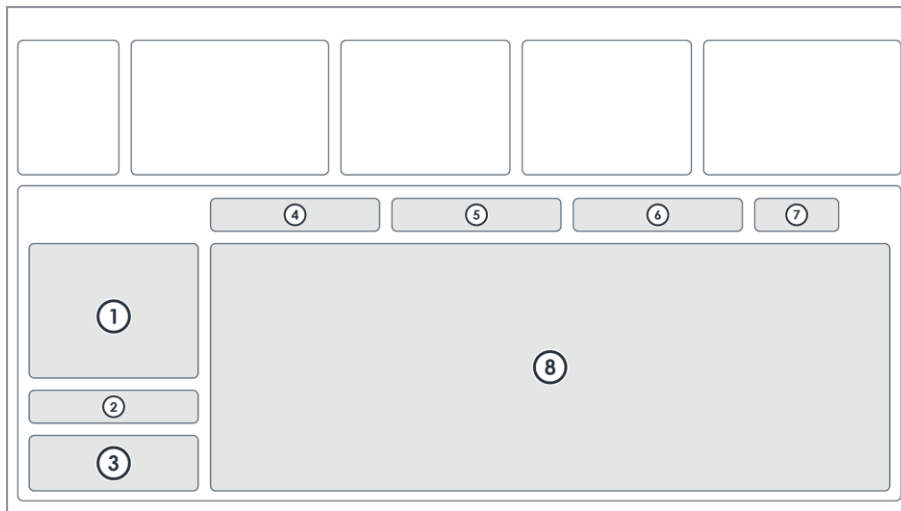

Fig. 28: Load Exposure Bitmaps frame

- | | | | |
|---|--------------------------|---|------------------|
| 1 | Expose Bitmaps Positions | 5 | Search |
| 2 | Edit | 6 | Show |
| 3 | Comment | 7 | Results |
| 4 | Load | 8 | Bitmap Templates |

Area	Description
Expose Bitmap Positions	Shows the index number, the x- and y-coordinates, and the name of the bitmaps.
Edit	<p>Edit and manage the bitmap settings and bitmap templates.</p> <ul style="list-style-type: none"> • New: Create a new bitmap template. • Copy: Copy the currently selected bitmap template. • Edit: Edit the currently selected bitmap template. • Save: Save the currently selected bitmap template with the current settings. • Delete: Delete the currently selected bitmap template.
Comment	Shows an optional comment.

Load	<p>Confirm or cancel the selection of the bitmap template.</p> <ul style="list-style-type: none"> • Load: Confirm the selection of the bitmap template and return to the <i>Setup Job</i> frame. • Cancel: Cancel the selection of the bitmap template and return to the <i>Setup Job</i> frame. • Refresh: Refresh the display of the <i>Bitmap Templates</i> table below.
Search	Enter a search query to search for bitmap templates.
Show	Limit the number of displayed bitmap templates or show more bitmap templates.
Results	Shows the number of loaded bitmap templates.
Bitmap Templates	<p>Shows the available bitmap templates.</p> <p>If you started a search, the table shows the matching search results.</p> <p>Click an entry to select the corresponding template.</p> <p>Click any column header to sort the entries in the table alphabetically.</p>

Tab. 20: Load Expose Bitmaps frame – Control and display elements

4.1.13 LOAD ALIGNMENT SETTINGS FRAME

This context-dependent frame shows the available alignment templates. In this frame, you select an alignment template, and you can check, update, and manage alignment templates.

The frame opens when you double-click the field below Alignment Settings in the Layer frame of the Setup Job frame.

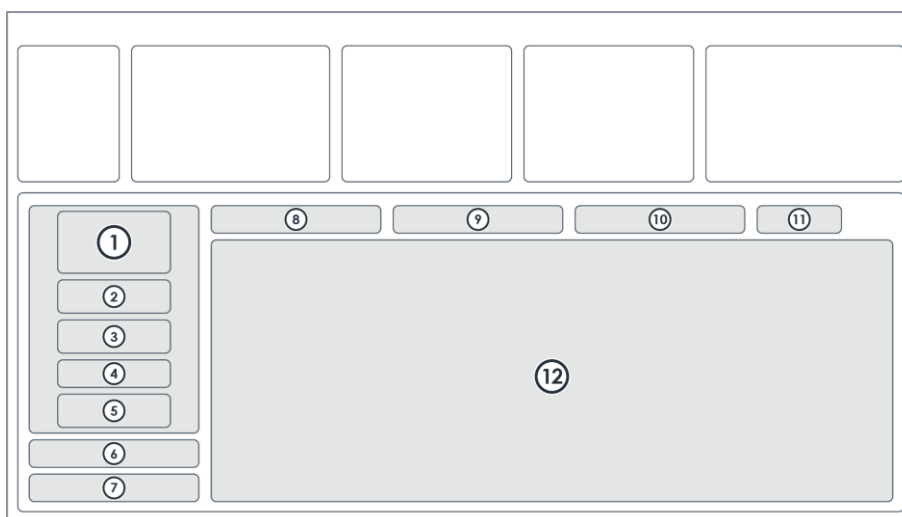

Fig. 29: Load Alignment Settings frame

- | | |
|------------------------------------|------------------------|
| 1 Alignment Cross Positions | 7 Comment |
| 2 Camera for Alignment | 8 Load |
| 3 Alignment Correction Options | 9 Search |
| 4 Move to Zero after last position | 10 Show |
| 5 Field Alignment | 11 Results |
| 6 Edit | 12 Alignment Templates |

Area	Description
Alignment Cross Positions	Shows the index number, the x-coordinate, and the y-coordinate of the alignment marks.
Camera for Alignment	Shows the camera mode that is used for the alignment procedure.
Alignment Correction Options	<p>Shows the options for alignment corrections.</p> <ul style="list-style-type: none"> • Rotation [mRad]: Use the substrate angle. The substrate angle represents the rotation of the substrate on the chuck. The system measured the substrate angle during the find center procedure. The alignment is rotated by substrate angle to compensate the substrate rotation. The substrate angle is particularly relevant for small substrates, which are usually difficult to load perfectly straight. • Scaling X / Y: Scale the aligned design. This option requires at least 3 measured alignment marks. The system compares the measured distance between the alignment marks. A scaling factor is calculated from the deviation. Based on the scaling factor, the aligned design is resized to the previous layer. • Shearing [mRad]: Compensate distortions. The system tries to compensate small distortions, such as rectangles that resemble a parallelogram.
Move to Zero after last position	Shows if the stage returns to the (0/0) position when the alignment is completed.
Field Alignment	Shows if a field alignment is executed. This option is only relevant if the field alignment mode is supported.
Edit	<p>Edit and manage the alignment templates.</p> <ul style="list-style-type: none"> • New: Create a new alignment template. • Edit: Edit the currently selected alignment template. • Save: Save the currently selected alignment template with the current settings. • Delete: Delete the currently selected alignment template.
Comment	Shows an optional comment.
Load	<p>Confirm or cancel the selection of the alignment template.</p> <ul style="list-style-type: none"> • Load: Confirm the selection of the alignment template and return to the Setup Job frame. • Cancel: Cancel the selection of the alignment template and return to the Setup Job frame. • Refresh: Refresh the display of the Alignment Templates table below.
Search	Enter a search query to search for alignment templates.

Show	Limit the number of displayed alignment templates or show more alignment templates.
Results	Shows the number of loaded alignment templates.
Alignment Templates	Shows the available alignment templates. If you started a search, the table shows the matching search results. Click an entry to select the corresponding template. Click any column header to sort the entries in the table alphabetically.

Tab. 21: Load Alignment Settings frame – Control and display elements

4.1.14 LOAD RESIST FRAME

This context-dependent frame shows the available resist templates. In this frame, you select a resist template and you can check, update, and manage resist templates.

The frame opens when you double-click the field below **Resist** in the Layer frame, the Series frame, or the Draw Mode frame of the Setup Job frame.

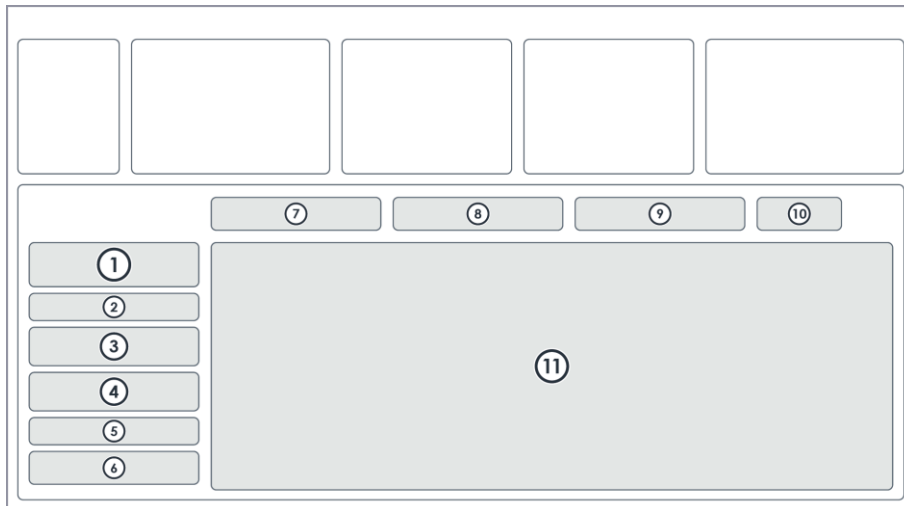

Fig. 30: Load Resist frame

- | | |
|--------------------------|---------------------|
| 1 Characteristics | 7 Load |
| 2 Grayvalue Optimization | 8 Search |
| 3 Exposure Parameters | 9 Show |
| 4 Process Parameters | 10 Results |
| 5 Edit | 11 Resist Templates |
| 6 Comment | |

Area	Description
Characteristics	Shows the parameters of the currently selected resist template.
Grayvalue Optimization	Shows options for resist optimization that are relevant if you expose grayscale designs.
Exposure Parameters	Shows the exposure parameters of the currently selected resist template.
Process Parameters	Shows the process parameters of the currently selected resist template.

Edit	<p>Edit and manage the resist templates.</p> <ul style="list-style-type: none"> • New: Create a new resist template. • Edit: Edit the currently selected resist template. • Save: Save the currently selected resist template with the current settings. • Delete: Delete the currently selected resist template.
Comment	Shows an optional comment.
Load	<p>Confirm or cancel the selection of the resist template.</p> <ul style="list-style-type: none"> • Load: Confirm the selection of the resist template and return to the Setup Job frame. • Cancel: Cancel the selection of the resist template and return to the Setup Job frame. • Refresh: Refresh the display of the Resist Templates table below.
Search	Enter a search query to search for resist templates.
Show	Limit the number of displayed resist templates or show more resist templates.
Results	Shows the number of loaded resist templates.
Substrate Templates	<p>Shows the available resist templates.</p> <p>If you started a search, the table shows the matching search results. Click an entry to select the corresponding template.</p> <p>Click any column header to sort the entries in the table alphabetically.</p>

Tab. 22: Load Resist frame – Control and display elements

4.1.15 LOAD SUBSTRATE <NAME> FRAME

This context-dependent frame guides you through the process of loading the substrate.

The frame opens when you click **Load Substrate** in the *Proceed* frame of the *Setup Job* frame.

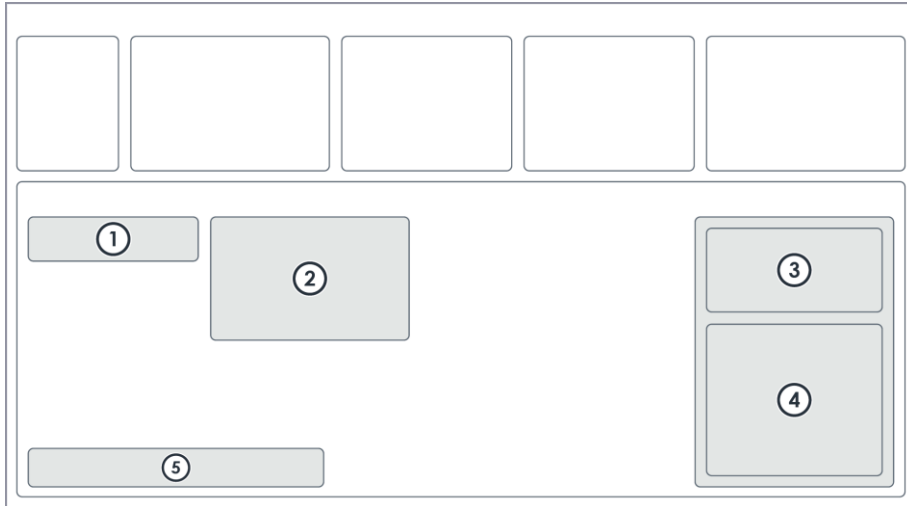

Fig. 31: Load Substrate <name> frame

- 1 Substrate Parameters (Selection)
- 2 Info
- 3 Camera Control
- 4 Stage Control
- 5 Proceed

Area	Description
Substrate Parameters (Selection)	Shows the parameters of the selected substrate. The parameters always include the name of the substrate and the autofocus mode that is set for the substrate. If relevant, additional parameters are shown that are set for the substrate, for example, if the find plate center procedure will be skipped.
Info	Shows tips and information about the process step.
Camera Control	Contains controls to select and control the cameras. These controls are disabled because the cameras are not relevant for this process step.
Stage Control	Contains controls to control the stage. These controls are enabled only for small substrates, for which you need to manually set the center of the substrate. For more information, see "8.6 Find substrate centers", page 143.

Proceed	<p>Proceed to the next process step:</p> <ul style="list-style-type: none"> • Continue: Confirm the position of the loaded substrate and proceed to the next step. Depending on the exposure procedure that you perform, the next frame opens, which is either the <i>First Exposure</i> frame, the <i>Alignment</i> frame, the <i>Series</i> frame, the <i>Draw Mode</i> frame, or the <i>Inspection Mode</i> frame. • Back: Return to the <i>Setup Job</i> frame to adjust the job settings. • Cancel: Cancel the job, unload the substrate, and return to the <i>Setup Job</i> frame.
---------	--

Tab. 23: Load Substrate <name> frame – Control and display elements

4.1.16 ALIGNMENT FRAME

This context-dependent frame shows the alignment settings. In this frame, you set the alignment settings for multi-layer exposures.

The frame opens when you select a layer that is not the First Exposure layer in the *Layer* frame of the *Setup Job* frame and click **Alignment** in the *Proceed* frame.

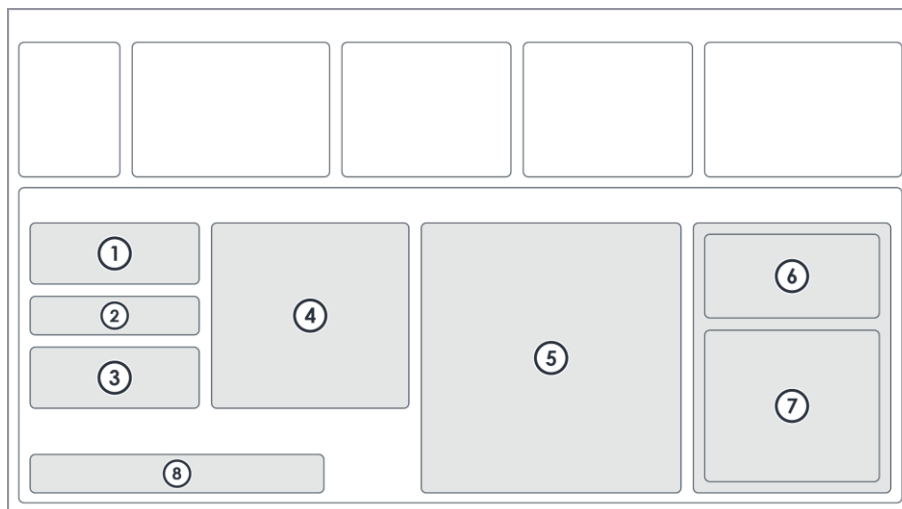

Fig. 32: Alignment frame

- | | |
|-----------------------------------|------------------|
| 1 Alignment Settings | 5 Substrate |
| 2 Move to First Cross / Use Angle | 6 Camera Control |
| 3 Cross Measurement | 7 Stage Control |
| 4 Info | 8 Proceed |

Area	Description
Alignment Settings	Shows the positions of the alignment marks. If you want to edit the parameters, click Edit .
Move to First Cross	Move the camera image to the first alignment mark.
Use Angle	Select whether to move to the first cross with or without taking the substrate angle into account.
Cross Measurement	Select a measurement method and set the measurement parameters.

Info	Shows tips and information about the process step.
Substrate	Shows a visual representation of the substrate, including horizontal and vertical dimensions. On the visual representation, you see the position of the camera view, the position of the alignment marks, and the position of the design.
Camera Control	Contains controls to select and control the cameras.
Stage Control	Contains controls to control the stage.
Proceed	Proceed to the next process step: <ul style="list-style-type: none"> • Continue: This button is disabled, because the control software automatically opens the <i>Alignment Exposure</i> frame when the alignment is completed. • Restart: Restart the alignment procedure. • Setup Job: Return to the <i>Setup Job</i> frame.

Tab. 24: Alignment frame – Control and display elements

4.1.17 FIRST EXPOSURE FRAME

This context-dependent frame shows the exposure settings. In this frame, you set the exposure settings for the exposure.

The frame opens when you select the First Exposure layer in the *Layer* frame of the *Setup Job* frame and click **First Exposure** in the *Proceed* frame. Also, the frame opens automatically when an alignment is completed in the *Alignment* frame.

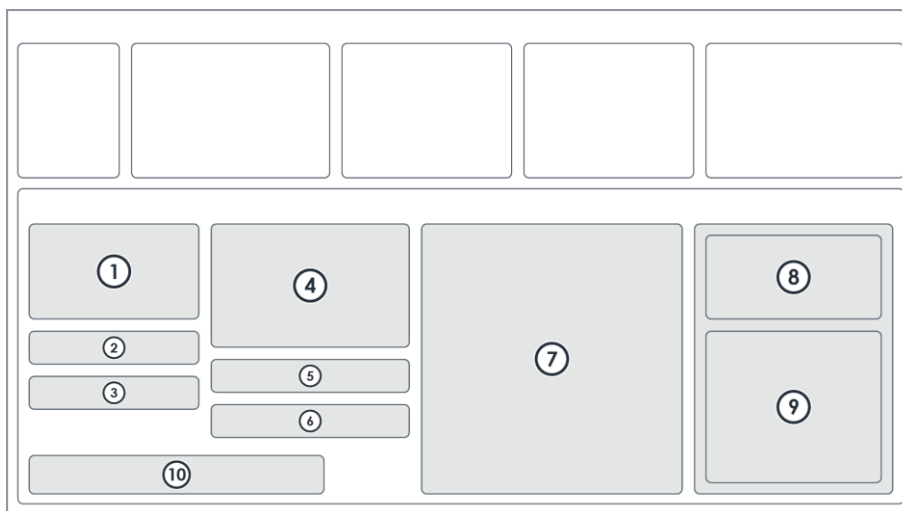

Fig. 33: First Exposure frame

- | | |
|------------------------------------|-------------------------|
| 1 Exposure Settings | 6 Comment |
| 2 Expose the Bitmaps | 7 Substrate |
| 3 Delay Exposure | 8 Camera Control |
| 4 Info | 9 Stage Control |
| 5 Auto-Unload the Substrate | 10 Proceed |

Area	Description
Exposure Settings	<p>Set the parameters for the exposure.</p> <p>The frame copies the settings from the <i>Setup Job</i> frame.</p> <p>The parameters include the design name, the laser that is used, the laser power and the other important settings.</p> <p>If required, select Expose with Substrate Angle.</p> <p>The substrate angle represents the rotation of the substrate on the chuck. The system measured the substrate angle during the find center procedure. The design is rotated by the substrate angle to compensate the substrate rotation.</p> <p>The substrate angle is particularly relevant for small substrates, which are usually difficult to load perfectly straight.</p>
Expose the Bitmaps	Shows options to expose the bitmaps of the selected bitmap template.
Delay Exposure	Set the waiting time before the exposure starts.
Info	Shows tips and information about the process step.
Auto-Unload the Substrate	Shows options to automatically unload the substrate when the exposure process is completed.
Comment	<p>Set an optional comment.</p> <p>The comment is saved for the current job and is shown in the <i>Setup Job</i> frame and in the <i>Exposure Info</i> frame.</p>
Substrate	<p>Shows a visual representation of the substrate, including horizontal and vertical dimensions.</p> <p>On the visual representation, you see the position of the camera view and the position of the design.</p>
Camera Control	Contains controls to select and control the cameras.
Stage Control	Contains controls to control the stage.
Proceed	<p>Proceed to the next process step:</p> <ul style="list-style-type: none"> • Start Exposure: Start the exposure. • Back: Return to the last process step. <p>This button is disabled, because the previous process step is fully completed and, thus, is not relevant anymore.</p> <ul style="list-style-type: none"> • Setup Job: Return to the <i>Setup Job</i> frame.

Tab. 25: First Exposure frame – Control and display elements

4.1.18 ALIGNMENT EXPOSURE FRAME

This context-dependent frame shows the exposure settings for an aligned exposure. In this frame, you set the exposure settings and the alignment settings.

The frame opens when you completed the global alignment for a multi-layer exposure.

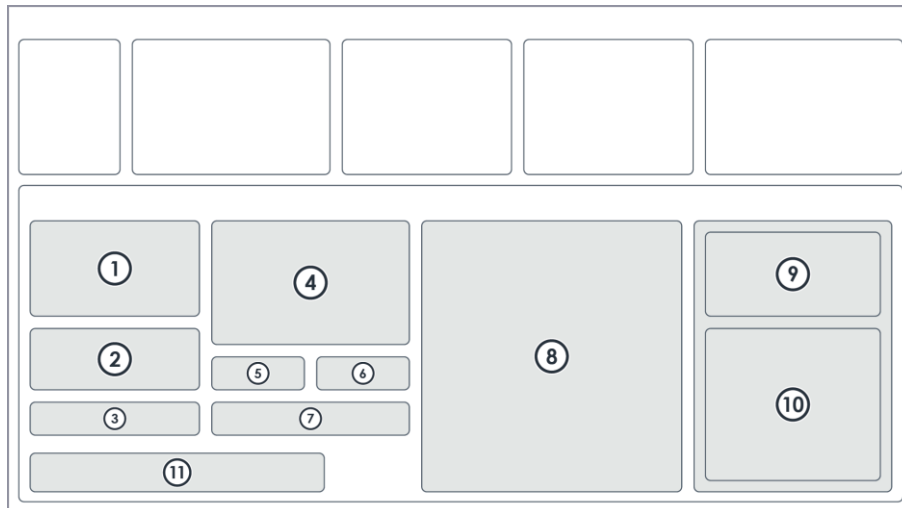

Fig. 34: Alignment Exposure frame

- | | |
|--------------------------------|------------------|
| 1 Exposure Settings | 7 Delay Exposure |
| 2 Alignment Correction Options | 8 Substrate |
| 3 Expose the Bitmaps | 9 Camera Control |
| 4 Info | 10 Stage Control |
| 5 Auto-Unload the Substrate | 11 Proceed |
| 6 Comment | |

Area	Description
Exposure Settings	Set the parameters for the aligned exposure. The frame copies the settings from the <i>Setup Job</i> frame. The parameters include, for example, the design name, the laser that is used, the laser power, and other important settings.
Alignment Correction Options	Correct the alignment if required: <ul style="list-style-type: none"> • Rotation: Select Use to use to rotate the aligned design. • Scaling X/Y: Select Use to scale the aligned design. This option requires at least 3 measured alignment marks. • Shearing: Select Use to compensate distortions. This option requires at least 4 measured alignment marks.
Expose the Bitmaps	Shows options to expose the prepared bitmaps, for example, additional alignment crosses.
Info	Shows tips and information about the process step.
Auto-Unload the Substrate	Select this option to automatically unload the substrate when the exposure process is completed.
Comment	Set an optional comment. The comment is saved for the current job and is shown in the <i>Setup Job</i> frame and the <i>Exposure Info</i> frame.
Delay Exposure	Set the waiting time before the exposure starts.

Substrate	Shows a visual representation of the substrate, including horizontal and vertical dimensions. On the visual representation, you see the position of the camera view and the position of the design.
Camera Control	Contains controls to select and control the cameras.
Stage Control	Contains controls to control the stage.
Proceed	Proceed to the next process step: <ul style="list-style-type: none"> • Start Exposure: Start the exposure. • Back: Return to the last process step. • Setup Job: Return to the <i>Setup Job</i> frame.

Tab. 26: Alignment Exposure frame – Control and display elements

4.1.19 SERIES FRAME

This context-dependent frame shows the exposure series settings. In this frame, you set the exposure settings for the exposure series.

The frame opens when you click **Series** in the *Proceed* frame of the *Setup Job* frame.

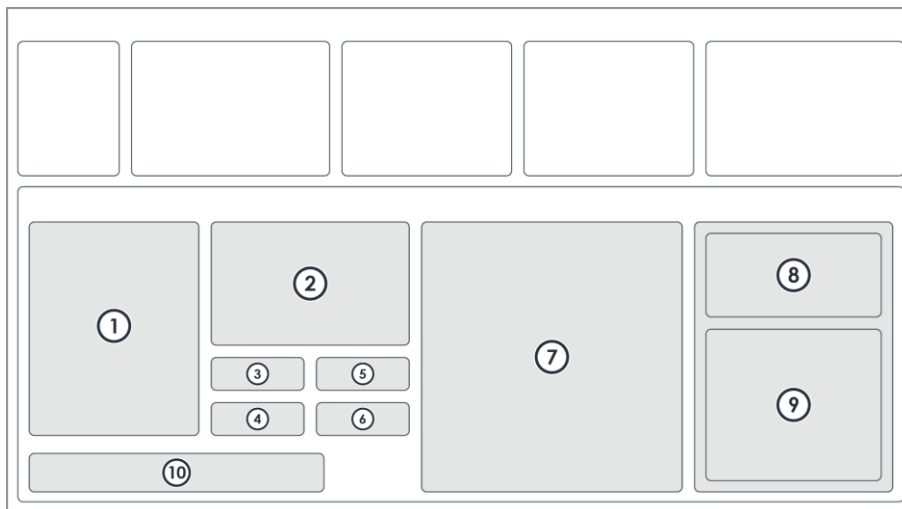

Fig. 35: Series frame

- | | |
|-------------------------|------------------|
| 1 Parameters | 6 Delay Exposure |
| 2 Info | 7 Substrate |
| 3 Expose Labeling | 8 Camera Control |
| 4 Comment | 9 Stage Control |
| 5 Auto-Unload Substrate | 10 Proceed |

Area	Description
Parameters	Set the parameters of the exposure series.
Info	Shows tips and information about the process step.
Expose Labeling	Select this option to expose labels for the exposure parameters below the design.

Comment	Set an optional comment. The comment is saved for the current job and is shown in the <i>Setup Job</i> frame and in the <i>Exposure History</i> frame.
Auto-Unload Substrate	Select this option to automatically unload the substrate when the exposure process is completed.
Delay Exposure	Set the waiting time before the exposure starts.
Substrate	Shows a visual representation of the substrate, including horizontal and vertical dimensions. On the visual representation, you see the position of the camera view and the position of the design.
Camera Control	Contains controls to select and control the cameras.
Stage Control	Contains controls to control the stage.
Proceed	Proceed to the next process step: <ul style="list-style-type: none"> • Start Exposure: Start the exposure. • Back: Return to the last process step. • Setup Job: Return to the <i>Setup Job</i> frame.

Tab. 27: Series frame – Control and display elements

4.1.20 DRAW MODE FRAME

This context-dependent frame shows the options for exposing an ad hoc shape. In this frame, you draw the ad hoc shape and set the exposure settings for the exposure.

The frame opens when you click **Draw Mode** in the *Proceed* frame of the *Setup Job* frame.

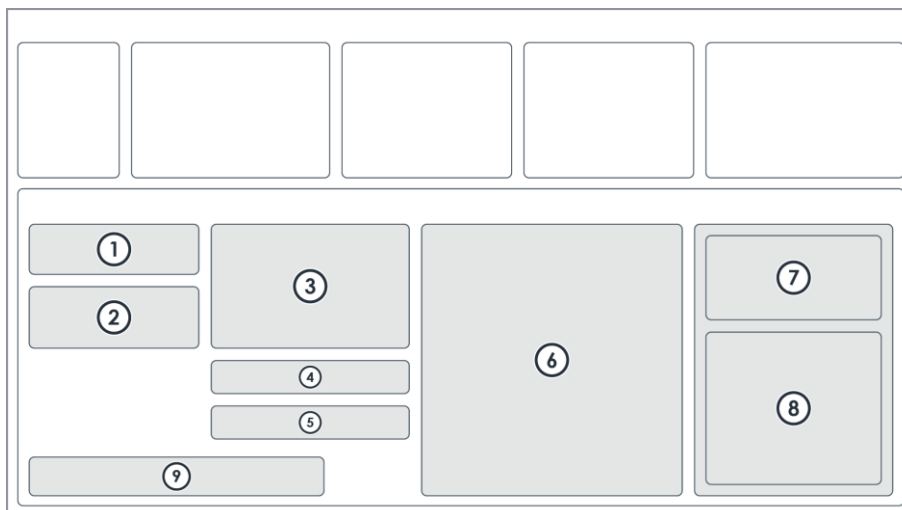

Fig. 36: Draw Mode frame

- | | |
|------------------------------------|-------------------------|
| 1 Exposure Settings | 6 Substrate |
| 2 Procedure | 7 Camera Control |
| 3 Info | 8 Stage Control |
| 4 Comment | 9 Proceed |
| 5 Auto-Unload the Substrate | |

Area	Description
Exposure Settings	Set the parameters for the exposure. The parameters include, for example, the design name, the exposure light source that is used, and other important settings.
Procedure	Select one of the available Draw Mode procedures.
Info	Shows tips and information about the process step.
Comment	Set an optional comment.
Auto-Unload the Substrate	Select this option to automatically unload the substrate when the exposure process is completed.
Substrate	Shows a visual representation of the substrate, including horizontal and vertical dimensions. On the visual representation, you see the position of the camera view.
Camera Control	Contains controls to select and control the cameras.
Stage Control	Contains controls to control the stage.
Proceed	Proceed to the next process step: <ul style="list-style-type: none"> • Start Exposure: Start the exposure. • Draw Image: Draw a shape in the camera window. This option is available only if you select Draw Image in the <i>Procedure</i> frame. • Set Point: Add a vector point in the camera window. This option is available only if you select Draw Line or Polygon in the <i>Procedure</i> frame. • Setup Job: Return to the <i>Setup Job</i> frame.

Tab. 28: Draw Mode frame – Control and display elements

4.1.21 INSPECTION MODE FRAME

This context-dependent frame shows the inspection settings.

The frame opens when you select **Inspection** from the **Job** drop-down list in the *Setup Job* frame and click **Continue** in the *Proceed* frame of the *Setup Job* frame.

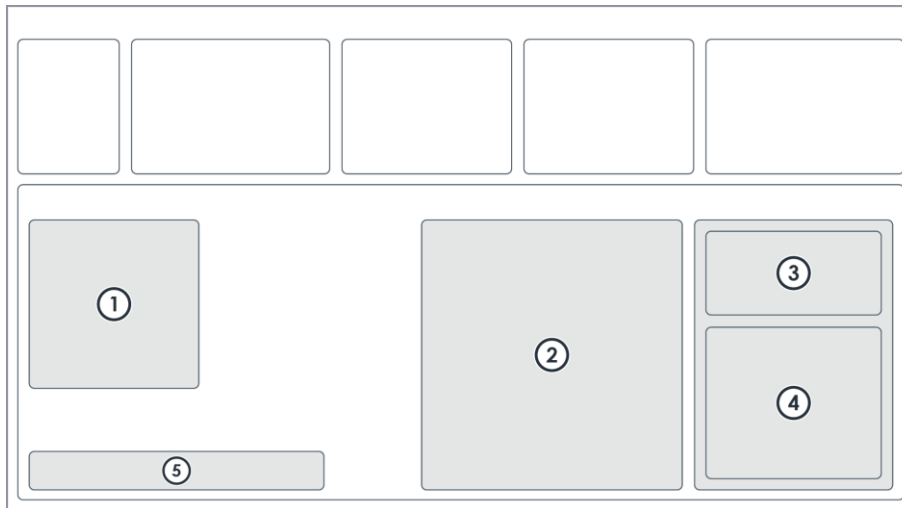

Fig. 37: Inspection Mode frame

- | | | | |
|---|----------------|---|---------------|
| 1 | Info | 4 | Stage Control |
| 2 | Substrate | 5 | Proceed |
| 3 | Camera Control | | |

The available areas, control elements, and display elements may vary depending on your user access rights.

Area	Description
Info	Shows tips and information about the process step.
Substrate	Shows a visual representation of the substrate, including horizontal and vertical dimensions. On the visual representation, you see the position of the camera view.
Camera Control	Contains controls to select and control the cameras.
Stage Control	Contains controls to control the stage.
Proceed	Proceed to the next process step: <ul style="list-style-type: none"> • Inspection: This button is disabled. • Back: This button is disabled. • Setup Job: Return to the <i>Setup Job</i> frame.

Tab. 29: Inspection Mode frame – Control and display elements

4.1.22 EXPOSURE HISTORY FRAME

This context-dependent frame shows the detailed activity log of the exposure processes. In this frame, you monitor the history of the exposure processes that were performed.

The frame opens when you select **Exposure History** from the *Info* menu in the menu bar.

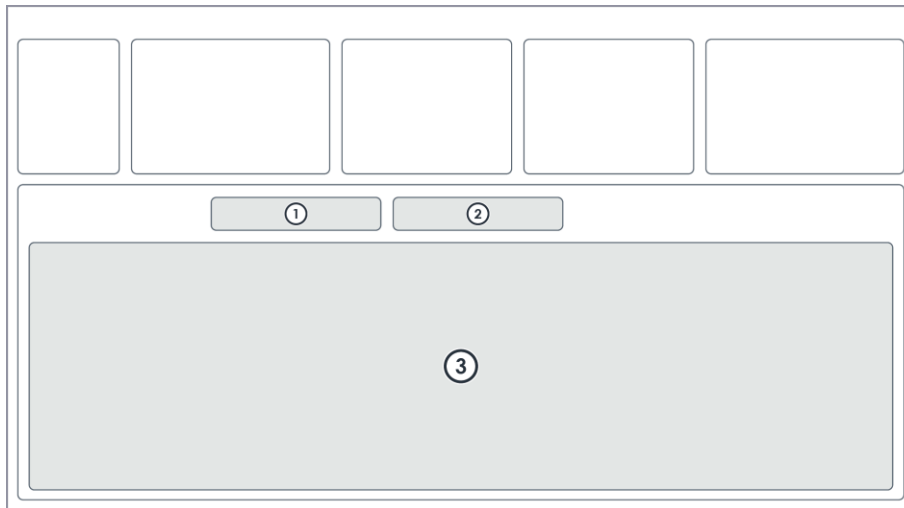

Fig. 38: Exposure History frame

- 1 Load
- 2 Search
- 3 Exposure History

Area	Description
Load	Perform one of the following actions: <ul style="list-style-type: none"> • Load: This button is disabled because the control software automatically loads the activity log when the frame opens. It may take a moment for the activity log to load. • Back: Return to the previous frame. • Refresh: Refresh the display of the <i>Exposure History</i> table below.
Search	Enter a search query to search for log entries.
Exposure History	Shows the activity log of the exposure processes that were performed.

Tab. 30: Exposure History frame – Control and display elements

4.1.23 STARTUP INFO FRAME

This context-dependent frame shows detailed system information that was logged during the startup process. In this frame, you can see the status of the system devices and the messages that were logged for the devices during the startup process.

The frame opens when you select **Startup Info** from the *Info* menu in the menu bar.

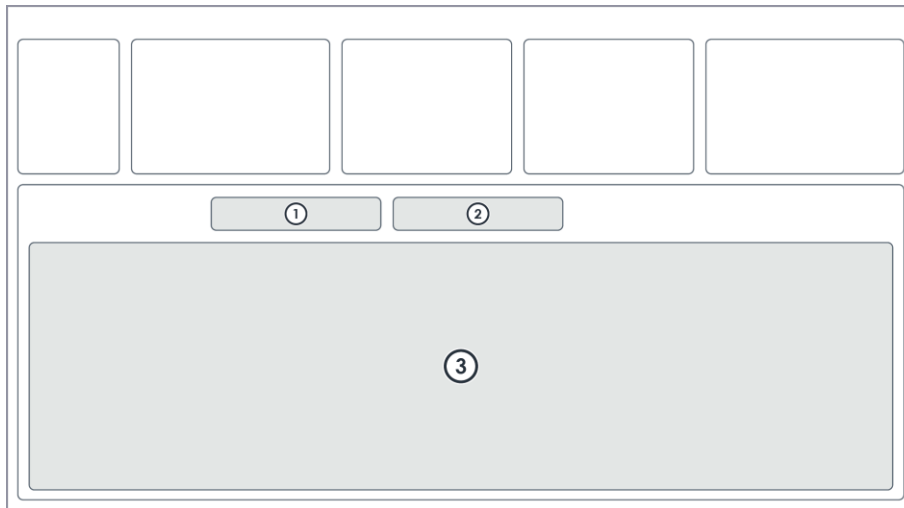

Fig. 39: Startup Info frame

- 1 Load
- 2 Search
- 3 Exposure Info

Area	Description
Load	Click Back to return to the previous frame.
Search	This input field is disabled.
Startup Info	Shows the status and the name of the system devices and the related log entries.

Tab. 31: Startup Info frame – Control and display elements

4.1.24 LASER MEASUREMENT FRAME

This context-dependent frame shows the laser measurement settings. In this frame, you set the measurement settings and measure the laser power or the exposure dose. Then, you can compare the measured value with the result of the last laser calibration. The measured results can point out issues caused by the laser and the optics. More detailed information on measurement of laser power and exposure dose you find in the *Maintenance Guide*.

The frame opens when you select **Laser Measurement** from the Tools menu in the menu bar.

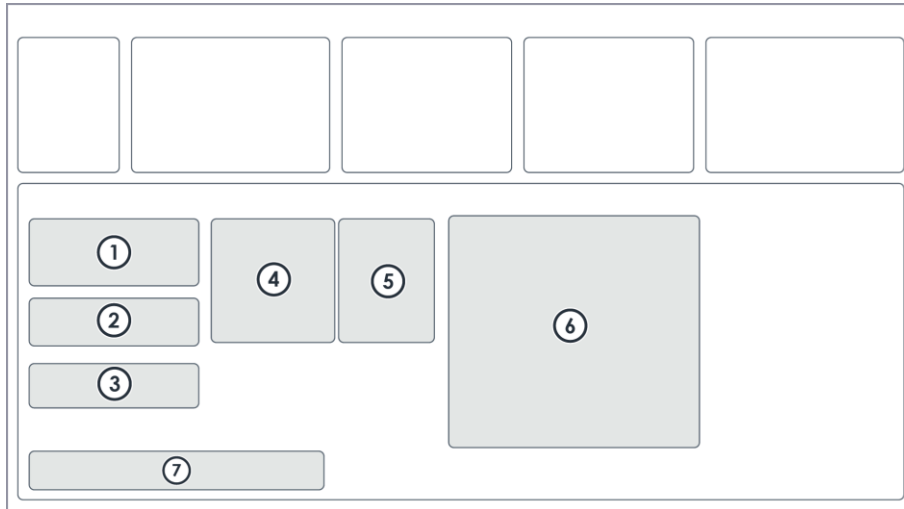

Fig. 40: Laser Measurement frame

- | | |
|------------|--------------------------|
| 1 Settings | 5 Intensity Measurements |
| 2 Controls | 6 Diode Scheme |
| 3 Results | 7 Proceed |
| 4 Info | |

Area	Description
Settings	Set the parameters of the laser measurement.
Controls	Contains controls to start the measurement process or to cancel it while it is running.
Results	Shows the results of the measurement.
Info	Shows tips and information about the process step.
Intensity Measurements	Shows a list of intensity measurements.
Diode Scheme	Shows a simplified representation of the diode measurement.
Proceed	Proceed to the next process step: <ul style="list-style-type: none"> • Continue: Proceed to the next step. • Unload Substrate: Unload the currently loaded substrate. • End Measurement: Finish the measurement process and return to the previous frame.

Tab. 32: Laser Measurement frame – Control and display elements

4.1.25 STAGE AND CAMERA CONTROL FRAME

This context-dependent frame contains controls to move the stage and control the cameras.

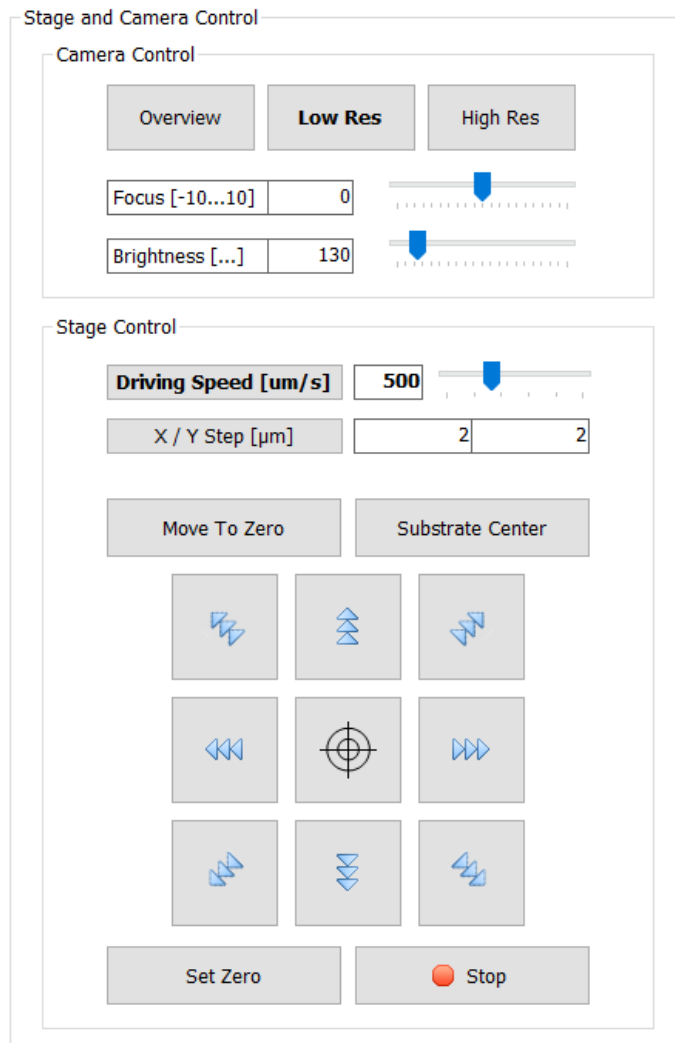

Fig. 41: Stage and Camera Control frame

CAMERA CONTROL FRAME

In the *Camera Control* frame, you can select the available cameras.

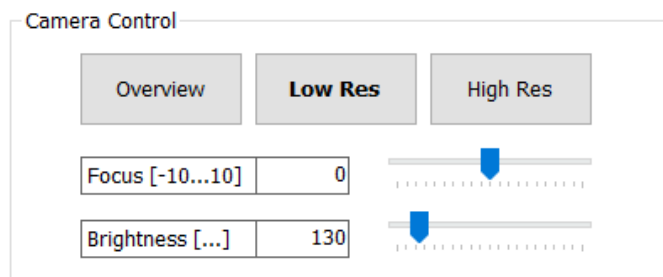

Fig. 42: Stage and Camera Control frame – Camera Control frame

Object	Description
Overview	Select the Overview Camera mode.
Low Res	Select the Low-Resolution Camera mode.
High Res	Select the High-Resolution Camera mode, which is recommended for alignment procedures.
Focus	Set the camera focus. Positive values mean the camera focus move closer to the substrate.
Range	Set the camera focus in the wider defocus range. This option is only available if you activate the wider defocus range. To activate the wider defocus range, select Tools » Large Camera Defoc from the menu bar. Then, the Focus field is replaced by the Range field.
Brightness	Set the brightness of the camera image.

Tab. 33: Camera Control frame – Control objects

STAGE CONTROL FRAME

In the *Stage Control* frame, you can move the stage.

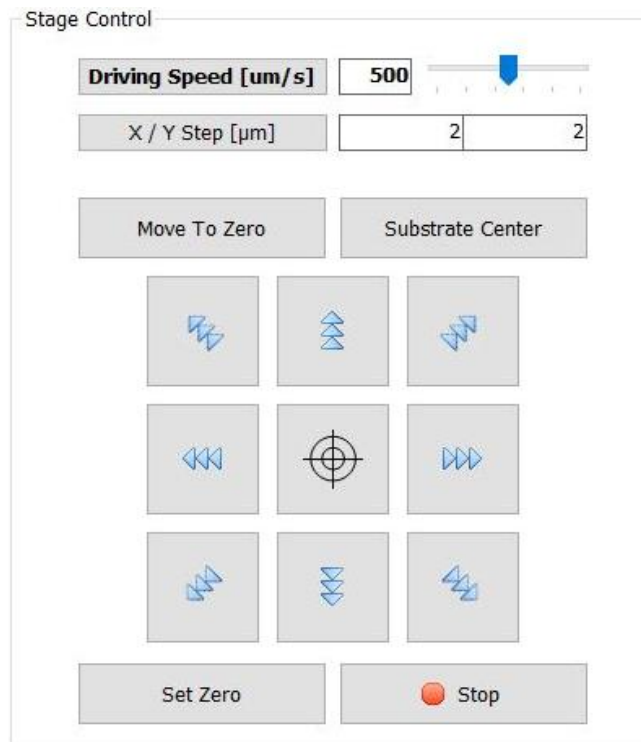



Fig. 43: Stage and Camera Control frame – Stage Control frame

Object	Description
Driving Speed	Select continuous stage movement (jog mode).
X/Y Step	Select stepwise stage movement (step mode).
Move To Zero	Move the stage to the (0/0) position.
Substrate Center	Move to the stage to the substrate center.

	Control the stage movement via the arrow buttons.
	Use a crosshair in the camera live view to specify the position to which you want to move the stage.
Set Zero	Set the current position as the (0/0) position (not available during alignment procedures).
Stop	Stop any stage movement.

Tab. 34: Stage Control frame – Control objects

4.2 Secondary window

The secondary window contains panels that you use to control the camera image and the cameras.

Note that this section may contain information about features, options, or objects that are available only to users with extended user access rights. For more information about user access rights, contact the system administrator.

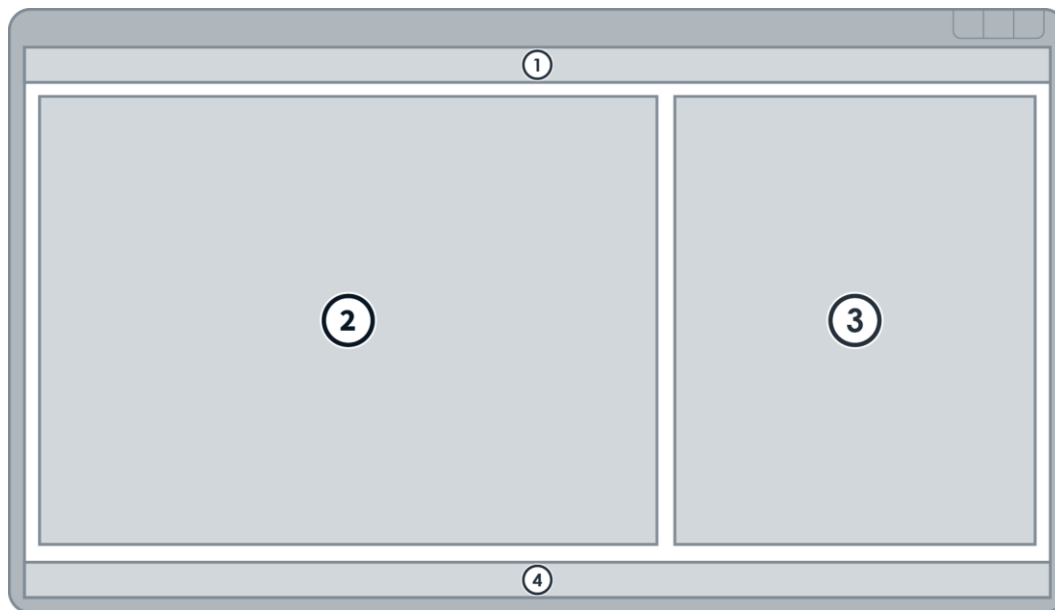



Fig. 44: Secondary window

- 1 Menu bar
- 2 Cameras
- 3 Devices
- 4 Status bar

You can resize the panels. Move the cursor between 2 panels. When you see the  icon, move the panel border to the desired location.

You also can rearrange the panels in the window. To move a panel, drag and drop the tab or the header bar in any direction.

4.2.1 MENU BAR

Object	Description
File	
Change User	Open the <i>Login</i> dialog box and log in with another user account.
Tools	
User Manager	Open the <i>Manage User Database</i> window.
Create System Backup	Open the file explorer and select a location to save the system backup.
Devices	
Optics	Open the <i><Device> Lamp</i> panel or the <i>Overview Camera Controller</i> panel.
Vision	Open the <i>Cameras</i> panel.
Window	
<panel name>	Switch between open panels. Only panels that are currently open are available.
Help	
Keyboard Shortcuts	Open the <i>Shortcuts</i> window and assign individual keyboard shortcuts.

Tab. 35: Secondary window – Menu bar

4.2.2 STATUS BAR

The status bar provides status information about the devices. On the left, you see the username of the currently logged in user.

4.2.3 CAMERAS PANEL

This panel contains controls for the cameras. In this panel, you can get a live the camera image, switch between cameras, and set points of interest.

The panel opens when you select **Devices » Vision » Cameras** from the menu bar.

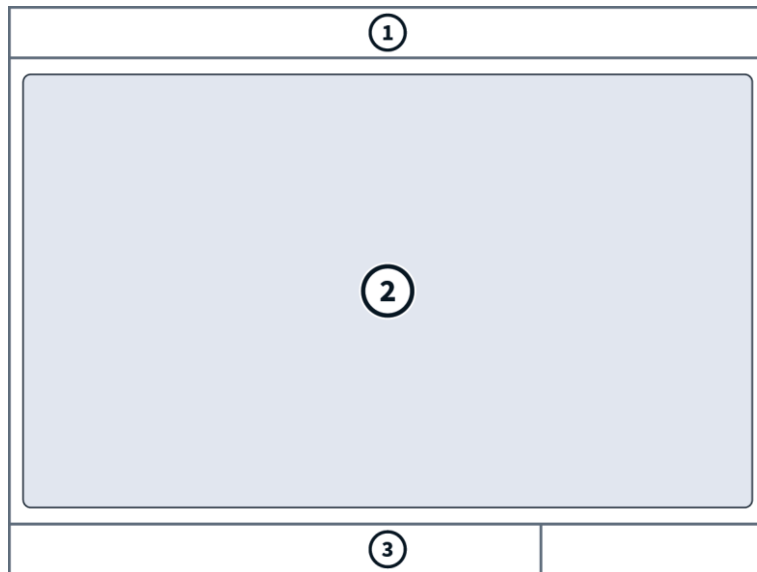

















Fig. 45: Cameras panel

- 1 Toolbars
- 2 Camera
- 3 Status bar

TOOLBARS

Object	Description
Main	
	<p>Activate or deactivate the secured mode for the device.</p> <p>In secured mode, the software disconnects the software controls from the device. Controlling the device via the software has no effect on the device.</p>
	<p>Initialize the device.</p> <p>If several devices are available, you can select individual devices or all devices.</p>
	<p>Refresh the display to the current data.</p>
	<p>Open the <i>Edit Control Settings for <Device></i> window and customize the panel.</p>
	<p>Show or hide the log area for the device.</p> <p>The log area shows recent information about the device. The log area is displayed on the right of the panel.</p> <p>Depending on the device, different log pages can be available. If more than one log page is available, you can switch between logs by selecting a log page at the top of the area.</p> <p>At the bottom of the log area, the following controls are available:</p> <ul style="list-style-type: none"> • Save: Save the log as a TXT-file. • Clear: Delete all log entries. • Autoscroll: Activate or deactivate automatic scrolling.

	Connect or disconnect the device.
Overlay Image	
	Draw a rectangle.
	Draw an ellipse.
	Draw a circle.
BMP	Load a bitmap file.
Clear	Remove the currently selected shape.
Load	Load a saved image.
Save	Save the current image.
Submit	Confirm the image.
Cancel	Abort the drawing process. The image is not saved.
Acquire	
	Start the live camera view and get a live camera image.
	Stop the live camera view.
	Take a snapshot of the current camera image. When you take a snapshot, the live camera view is automatically stopped.
	Measure a distance. Draw a straight line on the camera image to define the distance that you want to measure.
	Define an area of interest (AOI). Draw a rectangle on the camera image to define the area of interest.
Markers	
	Open the <i>Enter Marker Coordinates X, Y</i> dialog box and add a marker to the camera image. The origin of the coordinate system is the upper-left corner of the camera image. The coordinates are comma-separated values and are given in pixels.
	Remove markers from the camera image. You can select individual markers or all markers.
Template	
 Create	Create a new template from the camera view. Draw a rectangle on the camera image to define the relevant area and click  in the camera image. Then, set the template properties and confirm.
Manage	Open the <i>Template Manager</i> dialog box and edit, import, export, and delete templates.

Test	Open the <i>Select Template</i> dialog box and select the template that you want to test.
Tools	
	Take a screenshot of the current camera image. Save the snapshot as an image file on your local file system.
	Open the <i>Projection</i> dialog box and visualize the overall brightness along the x-axis or y-axis of the currently selected area of interest (AOI) as a graph.

Tab. 36: Toolbars

CAMERA FRAME

The frame shows the live camera image of the selected camera.

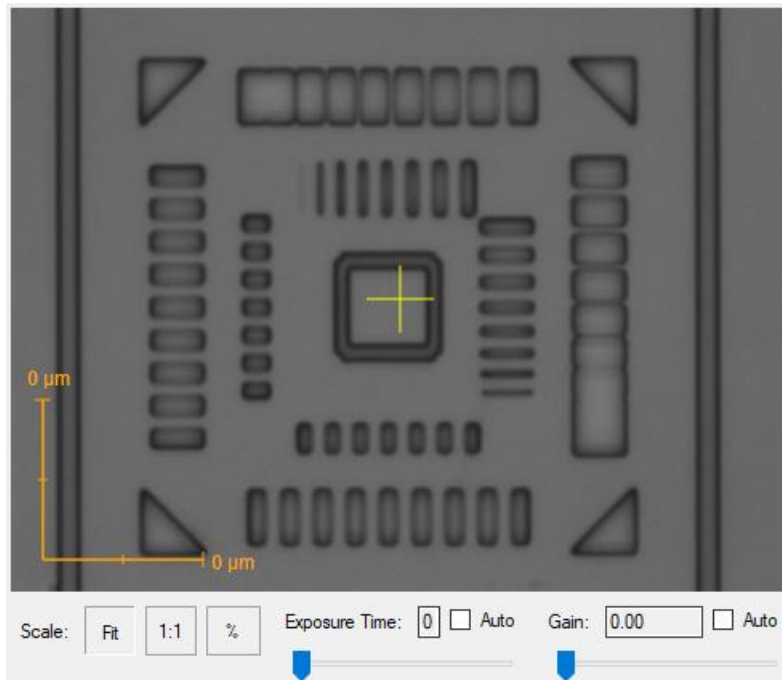

Fig. 46: Cameras panel – Camera frame

Object	Description
Scale	Resize the camera image: <ul style="list-style-type: none"> Fit: Scales the field of view to camera image to fit the frame. 1:1: Scales the field of view to the original camera resolution. %: Zooms the field of view up to 200%.
Exposure Time	Set the exposure time in milliseconds. Note that the unit of measurement for the exposure time can vary depending on the make and model of the camera. You can either set a value or move the slider. Double-click to make the field editable. Then, the field is highlighted with red color. Change the value and press Enter to confirm. Select Auto to automatically regulate the exposure time.

<p>Gain</p>	<p>Set the sensitivity of the camera image by changing the camera speed to brighten the image if needed.</p> <p>You can either set a value or move the slider.</p> <p>Double-click to make the field editable. Then, the field is highlighted with red color. Change the value and press Enter to confirm.</p> <p>Select Auto to automatically regulate the sensitivity of the camera image.</p>
--------------------	---

Tab. 37: Camera frame – Control and display objects

Additionally, you have the following options:

- Right-click a particular position on the camera image to add a marker.
- Right-click a marker to remove the marker.

STATUS BAR

At the right of the status bar, you see the x/y-coordinates of the current cursor position in the camera image. The origin of the coordinate system is the upper-left corner of the camera image.

4.2.4 <DEVICE> LAMP PANEL

The panel contains controls to control the lamp of a device.

You open the panel by clicking **Devices » Optics » <Device> Lamp** in the menu bar.

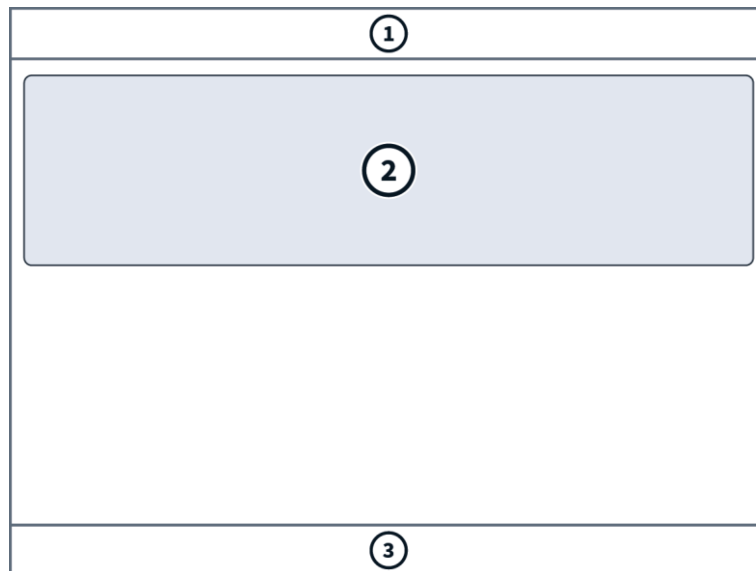

Fig. 47: <Device> Lamp panel

- 1 Toolbar
- 2 Lamp Control

3 Status bar

Object	Description
Toolbar	
	<p>Activate or deactivate the secured mode for the device.</p> <p>In secured mode, the software disconnects the software controls from the device. Controlling the device via the software has no effect on the device.</p>
	<p>Initialize the device.</p> <p>If several devices are available, you can select individual devices or all devices.</p>
	Refresh the display to the current data.
	Open the <i>Edit Control Settings for <Device></i> window and customize the panel.
	<p>Show or hide the log area for the device.</p> <p>The log area shows recent information about the device. The log area is displayed on the right of the panel.</p> <p>Depending on the device, different log pages can be available. If more than one log page is available, you can switch between logs by selecting a log page at the top of the area.</p> <p>At the bottom of the log area, the following controls are available:</p> <ul style="list-style-type: none"> • Save: Save the log as a TXT-file. • Clear: Delete all log entries. • Autoscroll: Activate or deactivate automatic scrolling.
Status bar	
<status>	Provides status information about the device.

Tab. 38: Control and display objects

LAMP CONTROL FRAME

The frame contains controls to control the lamp of a device.

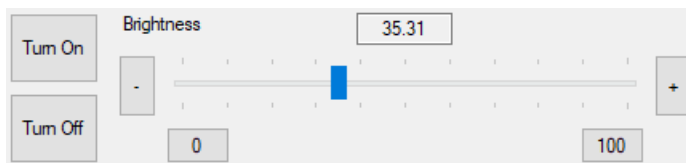



Fig. 48: <Device Lamp> panel – Lamp Control frame

Object	Description
Brightness	<p>Control the brightness of the lamp.</p> <p>You can either set a value or move the slider.</p> <p>Double-click to make the field editable. Then, the field is highlighted with red color. Change the value and press Enter to confirm.</p>
Turn on	Turn on the lamp.

Turn off	Turn off the lamp.
 / 	Indicates whether the lamp is turned on or turned off.

Tab. 39: Lamp Control frame – Control and display objects

4.2.5 OVERVIEW CAMERA CONTROLLER PANEL

The panel contains controls to control the focus of the overview camera.

You open the panel by clicking **Devices » Optics » Overview Camera Controller** in the menu bar.

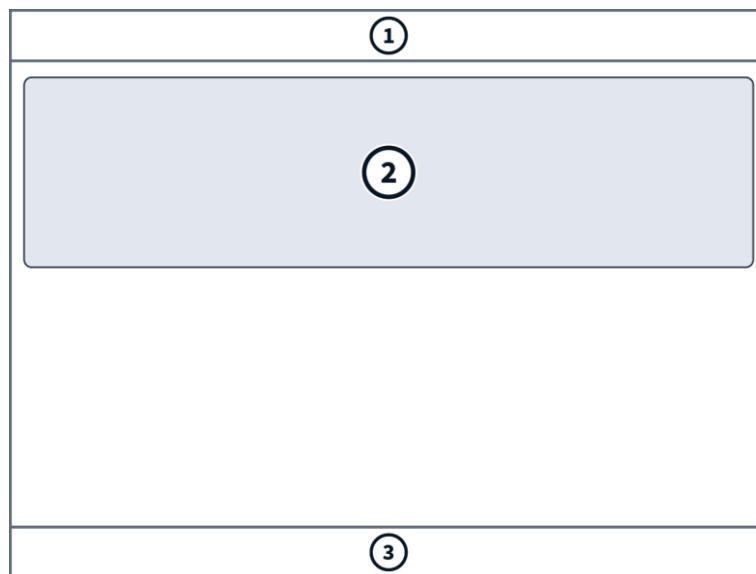







Fig. 49: Overview Camera Controller panel

- 1 Toolbar
- 2 Overview Camera Control
- 3 Status bar

Object	Description
Toolbar	
	Activate or deactivate the secured mode for the device. In secured mode, the software disconnects the software controls from the device. Controlling the device via the software has no effect on the device.
	Initialize the device. If several devices are available, you can select individual devices or all devices.
	Refresh the display to the current data.
	Open the <i>Edit Control Settings for <Device></i> window and customize the panel.

	<p>Show or hide the log area for the device.</p> <p>The log area shows recent information about the device. The log area is displayed on the right of the panel.</p> <p>Depending on the device, different log pages can be available. If more than one log page is available, you can switch between logs by selecting a log page at the top of the area.</p> <p>At the bottom of the log area, the following controls are available:</p> <ul style="list-style-type: none"> • Save: Save the log as a TXT-file. • Clear: Delete all log entries. • Autoscroll: Activate or deactivate automatic scrolling.
	<p>Connect or disconnect the device.</p>
<p>Status bar</p>	
<p><status></p>	<p>Provides status information about the device.</p>

Tab. 40: Control and display objects

OVERVIEW CAMERA CONTROL FRAME

The frame contains controls to control the focus of the overview camera.

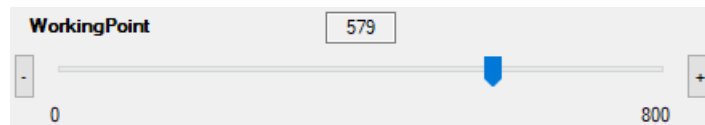

Fig. 50: <Device Lamp> panel – Overview Camera Control frame

Object	Description
<p>Working point</p>	<p>Control the focus of the overview camera.</p> <p>You can either set a value or move the slider.</p> <p>Double-click to make the field editable. Then, the field is highlighted with red color. Change the value and press Enter to confirm.</p>

Tab. 41: Overview Camera Control frame – Control and display objects

5 Turn on/off the system

NOTE

This section may contain information about features, options, or objects that are not available for your system.

For information about your system specification, see the Technical Datasheet.

You find the main switches and the system power controls at the side of the step-up transformer and at the front of the power supply rack in the electronics cabinet.

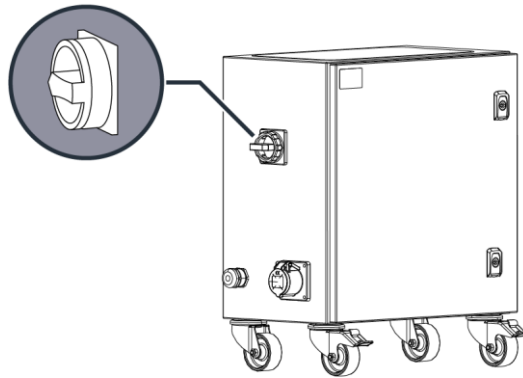

Fig. 51: Main switch at the step-up transformer

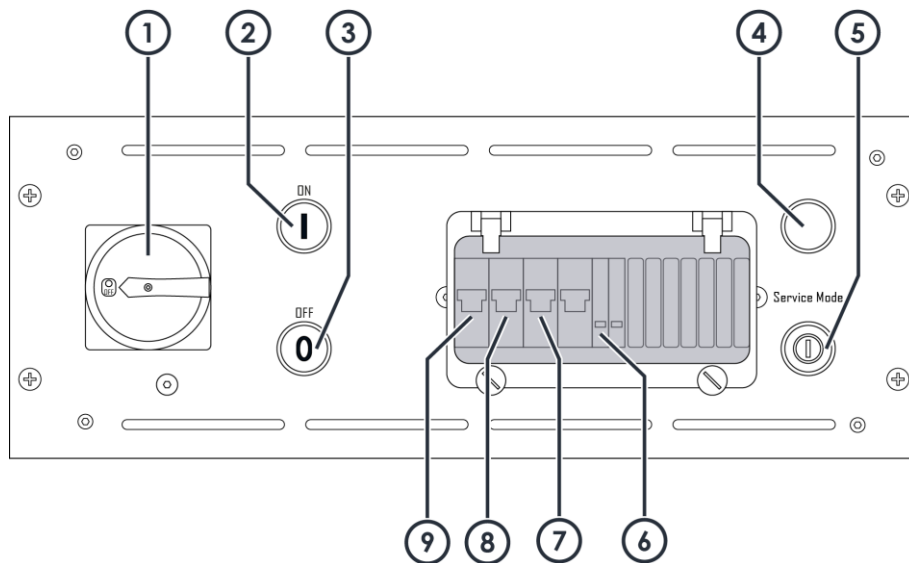

Fig. 52: Power controls at the power supply rack

- | | | | |
|---|-------------------------|---|---------------------------|
| 1 | Main switch | 6 | Power LED |
| 2 | ON button | 7 | Main power fuse |
| 3 | OFF button | 8 | Interferometer power fuse |
| 4 | Service mode lamp | 9 | 24 V control power fuse |
| 5 | Service mode key switch | | |

For more information, see "3.5 Electronics cabinet", page 25.

5.1 Turn on the system

Note that the following instruction may contain steps related to features, options, or objects that are not available for your system. Skip the steps that are not relevant for you.

NOTICE

Risk of malfunction and exposure quality loss.

If you start exposing before all components are properly warmed up and the system is temperature stable, the exposure quality decreases and errors can occur.

Make sure to comply with the warm-up times given in the instructions.

Perform the following steps to turn on the system:

1. Turn the main switch at the step-up transformer to the ON position.
This step is only relevant for systems equipped with a step-up transformer.
2. Turn the main switch at the power supply rack to the ON position.
 - ✓ The machine is supplied with power.
3. Wait 20 seconds.
 - ✓ The power supply boots up.
 - ✓ The safety system is freed.
 - ✓ The machine is in safe mode.
4. Press the **On** button.
 - ✓ The **Power** LED lights up.
 - ✓ The machine starts up.

NOTE

If the heater overheats during startup, the heater is turned off. Then, the **Temperature Reset** button lights up next to the temperature controller.

To turn on the heater again, press the **Temperature Reset** button.

5. Make sure that the external chiller is turned on.
To turn on the external chiller, follow the instructions of the manufacturer.
 - ✓ Temperature regulation of the environmental chamber starts.
6. Switch on the user PC.
7. Switch on the conversion PC.
8. Switch on the screens.
9. Start the control software.
For more information, see "6.1 Start the software", page 77.

10. Check the temperature controller and wait until the system is temperature stable.

- ✓ After approximately 30 minutes, the machine reached a stable condition.
- ✓ The temperature is stable at the target temperature.

Now, you can start your work session.

5.2 Put the system to standby mode

To switch off the machine normally, put the machine to standby mode. In standby mode, the temperature regulation remains on and temperature stability is ensured. It is not recommended to turn off the machine completely.

Perform the following steps to put the system to standby mode:

1. Make sure to remove substrates and other objects from the chuck.
2. Select **File** » **Exit** from the menu bar of the control software.
 - ✓ You see the desktop of the user PC.
3. Press the power button of the conversion PC.
 - ✓ The conversion PC is switched off.
4. Shut down the operating system of the user PC.
 - ✓ The user PC is switched off.
5. Press the **Off** button.
 - ✓ The **Power** LED no longer lights up.

Now, the machine is in standby mode.

5.3 Shut down the system

Note that the following instruction may contain steps related to features, options, or objects that are not available for your system. Skip the steps that are not relevant for you.

NOTE

Temperature stability is not ensured when the machine is shut down.

It is not recommended to shut down the machine completely, except for servicing. Temperature stability is no longer ensured when the machine is turned off.

To switch off the machine normally, put the machine to standby mode.

Perform the following steps to shut down the system:

1. Put the system to standby mode.
 - For more information, see "5.2 Put the system to standby mode", page 75.
 - ✓ The machine is put into standby mode.
 - ✓ The **Power** LED no longer lights up.
2. Turn the main switch at the power supply rack to the OFF position.
3. Turn the main switch at the step-up transformer to the OFF position.

4. If the system is to be serviced, secure the main switch with a padlock.

If your system is equipped with a step-up transformer, secure the main switch at the transformer with a padlock.

This step is only relevant for systems that are equipped with a step-up transformer.

If the system is not equipped with a step-up transformer, secure the main switch at the power supply rack in the electronics cabinet with a padlock.

Now, the machine is completely turned off.

⚠ WARNING

Risk of electrical shock.

Secure the main switch with a padlock prior servicing.

Servicing may be carried out by trained and authorized HIMT engineers only.

5.3.1 RESTART THE SYSTEM AFTER EMERGENCY SHUT-OFF

Note that the following instruction may contain steps related to features, options, or objects that are not available for your system. Skip the steps that are not relevant for you.

Perform the following steps to restart the system after an emergency shut-off:

1. Turn the emergency shut-off switch in the direction that is indicated on the switch.
 - ✓ The emergency shut-off switch is released.
2. Make sure that the main switch is in the ON position.
3. Press the **On** button.
 - ✓ The **Power** LED lights up.
 - ✓ The machine is readying for operation.
4. Make sure that the external chiller is turned on.
 - To turn on the external chiller, follow the instructions of the manufacturer.
 - ✓ Temperature regulation of the environmental chamber starts.
5. Check the temperature controller and wait until the system is temperature stable.
 - The required warm-up time depends on how long the machine was turned off.
 - ✓ The temperature is stable at the target temperature.

Now, you can resume the operation.

6 Start/end work sessions

6.1 Start the software

Before you can start your work session, you must start the control software. Via the control software, you operate, control, and monitor the system.

- Click ^{HINT} **MLA** in the Windows taskbar of the user PC.
- ✓ The control software starts.
- ✓ You see the initialization status of the system components in the Hardware Info frame.

You are automatically logged in with the **Standard** user role. The **Standard** user role is the user role for operators, who operate, control, and monitor the system. Further user roles with extended user rights are available. For more information, see "6.5 Change users", page 78.

6.2 Log in

When the control software starts, you are automatically logged in with the standard user account for operators. Logging in with a different user account is only necessary if maintenance or administration tasks must be performed on the system.

If you want to log in with a different user account, you can change the user account. For more information, see "6.5 Change users", page 78.

6.3 Create jobs

Perform the following steps to create a new job:

1. If the *Setup Job* frame is not shown in the control software, go to the *Setup Job* frame.

When you start the control software, the *Setup Job* frame opens automatically and automatically creates a new, blank job. Then, skip the next step.

- ✓ You see the *Setup Job* frame in the control software.
2. Click **New Job** in the *Job* frame.
 - ✓ A new, blank job opens in the *Setup Job* frame.
 3. Click the field below **Name** in the *Job* frame.
 4. Enter the name that you want to use for the job.
 5. Press the Enter key to confirm.

Now, you can continue with the exposure process. For more information, see the instruction for the operation that you want to perform.

6.4 Load jobs

Perform the following steps to load an existing job:

1. If the *Setup Job* frame is not shown in the control software, go to the *Setup Job* frame.
 - ✓ You see the *Setup Job* frame in the control software.
2. Click **Load Job** in the *Job* frame.
 - ✓ A dialog box opens.
3. Select the job that you want to use.
4. Click **OK** to confirm.
 - ✓ You see the parameters of the loaded job in the *Setup Job* frame.

Now, you can continue with the exposure process. For more information, see the instruction for the operation that you want to perform.

6.5 Change users

When the control software starts, you are automatically logged in with the standard user account for operators. Changing the user account is only necessary if maintenance or administration tasks must be performed on the system.

Perform the following steps if you need to change the user account:

1. Select **User Management » Change user** from the menu bar.
 - ✓ The *UserLogin* dialog box opens.
2. Select the required user account from the **Username** dropdown list.

The following list shows the standard user accounts:

- **Standard:** This is the user account for operators, who operate, control, and monitor the system.
- **Staff:** This user account is restricted to the maintenance staff, who carries out regular maintenance and administration tasks on the system.
- **Service:** This user account is restricted to Heidelberg Instruments Mikrotechnik service engineers, who carry out service, maintenance, and repair tasks on the system.

3. Enter the password in the **Password** field.

If you selected the **Standard** user account, skip this step. The **Standard** user account does not require a password.

4. Click **Login** to confirm.
 - ✓ The *UserLogin* dialog box closes.

Now, you are logged in with the selected user account.

6.6 Log out

When you end your work session, you log out of your user account. Logging out is only necessary if you are logged in with the staff user account or the service user account.

Perform the following steps to log out of your user account.

- Select **User Management » Change User** from the menu bar.
- ✓ The *UserLogin* dialog box opens.
- ✓ You are logged out of your user account.

Now, another user can log in and start a work session.

7 Load/unload substrates

This chapter explains the loading and unloading procedure step by step.

Before you start an application, choose the appropriate substrate. Load the substrate by placing it on the chuck. After the application is completed, unload the substrate.

NOTE

The following instructions concern the standard chuck layout. The chuck is exchangeable to meet the requirements of your application.

For more information, contact the system administrator or the HIMT Service.

To achieve best results, make sure that the required conditions are given:

- The environment must be steady and kept at a constant temperature and humidity.
The temperature within the system should be equal to the temperature of the environment.
- The substrates require thermal stabilization before being processed.
The time required depends on the material and thickness of the substrates.
- The chuck must be clean. Dirt or dust on the chuck cause vacuum losses.
You can clean the chuck with a dry, clean wipe or, if necessary, with industry-grade ethanol or isopropanol. Do not use acetone or other cleaning agents containing solvents.

7.1 Load substrates

7.1.1 LOAD SMALL SUBSTRATES

Perform the following steps to place the substrate onto the chuck:

1. Start the loading process in the control software.
For more information, see the instruction for the operation that you want to perform.
2. Make sure that the white light is switched off.
- ✓ Only the appropriate safelight is switched on.
3. Take the substrate out of the container.
4. Open the loading window.

- Place the adjustment aid for small substrates at the center of the chuck.

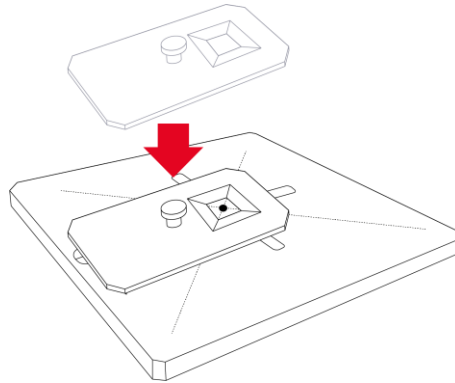

Fig. 53: Place the adjustment aid for small substrates

- Carefully place the substrate correctly oriented in the hole of the adjustment aid.

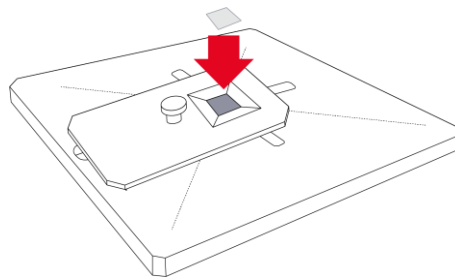

Fig. 54: Place the substrate in the adjustment aid

- Press the **Push** button at the operator panel to switch on the vacuum.
- Remove the adjustment aid from the chuck.

To prevent damage of the system, the system blocks the stage movement if the adjustment aid is still on the chuck.

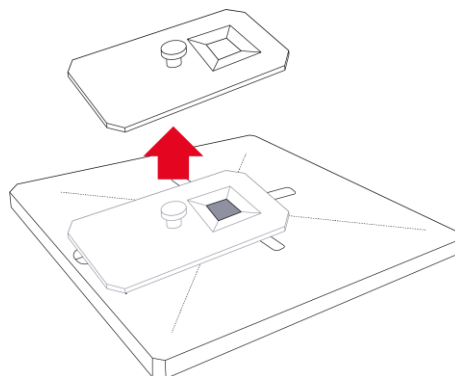

Fig. 55: Remove the adjustment aid.

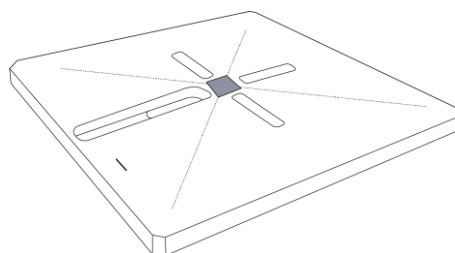

Fig. 56: Correctly aligned substrate

9. Make sure that the substrate is held firmly in place.
✓ When you gently try to push the substrate sideways, the substrate does not move.

Troubleshooting if the substrate moves:

- Check the stage and the substrate for dirt.
- Check the substrate for scratches.
- Try using a different substrate.

10. Close the loading window.

Now, you can complete the loading process in the control software. Continue with the instruction for the operation that you want to perform.

7.1.2 LOAD MEDIUM-SIZED SUBSTRATES

Perform the following steps to place the substrate onto the chuck:

1. Start the loading process in the control software.
For more information, see the instruction for the operation that you want to perform.
2. Make sure that the white light is switched off.
- ✓ Only the appropriate safelight is switched on.
3. Take the substrate out of the container.
4. Open the loading window.
5. Place the adjustment aid for medium-sized substrates into the corresponding recess of the chuck.

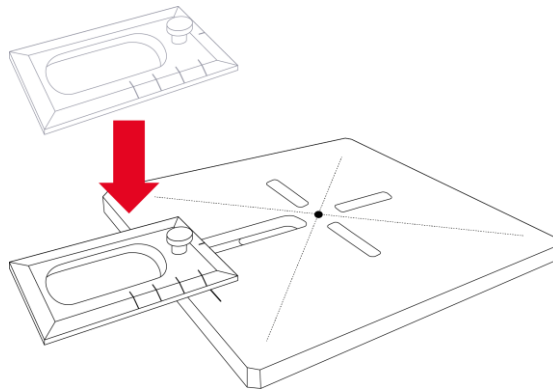

Fig. 57: Place the adjustment aid for medium-sized substrates

The scale on the adjustment aid shows the optimum distances to center substrates of different sizes and helps you to load the substrate correctly.

6. Align the appropriate marking line of the scale on the adjustment aid and the marking line on the chuck.

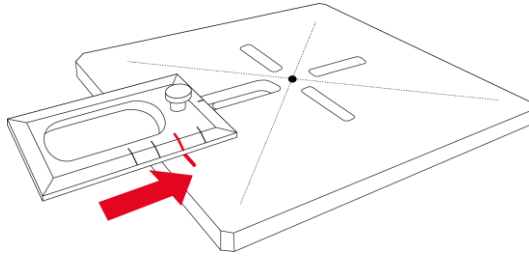

Fig. 58: Align the adjustment aid

7. Carefully place the substrate correctly oriented on the stage.
8. Align the edge of the substrate with the edge of the adjustment aid.

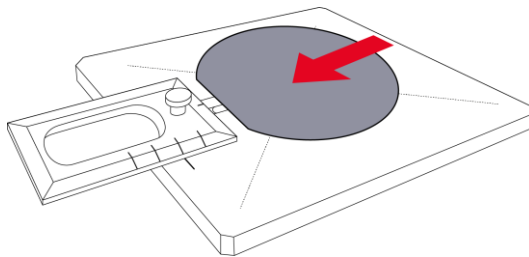

Fig. 59: Align the substrate

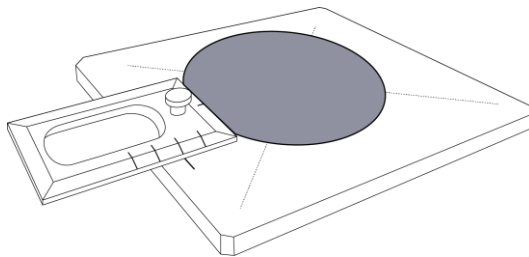

Fig. 60: Correctly aligned substrate

9. Press the **Push** button at the operator panel to switch on the vacuum.
 10. Make sure that the substrate is held firmly in place.
- ✓ When you gently try to push the substrate sideways, the substrate does not move.

Troubleshooting if the substrate moves:

- Check the stage and the substrate for dirt.
- Check the substrate for scratches.
- Try using a different substrate.

11. Remove the adjustment aid from the chuck.

To prevent damage of the system, the system blocks the stage movement if the adjustment aid is still on the chuck.

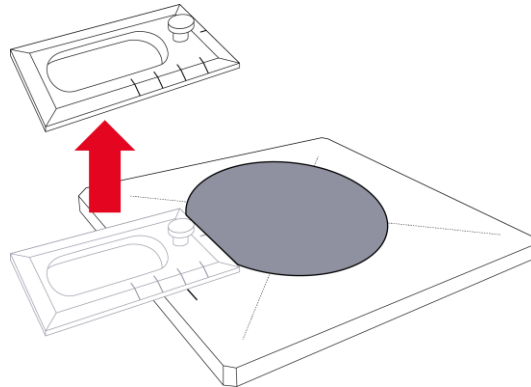

Fig. 61: Remove the adjustment aid.

12. Close the loading window.

Now, you can complete the loading process in the control software. Continue with the instruction for the operation that you want to perform.

7.1.3 LOAD LARGE SUBSTRATES

Note that the following instruction is relevant only for systems with an exposure area upgrade. For information about your systems specifications, see the Technical Datasheet.

Perform the following steps to load the substrate:

1. Start the loading process in the control software.
For more information, see the instruction for the operation that you want to perform.
2. Make sure that the white light is switched off.
- ✓ Only the appropriate safelight is switched on.
3. Take the substrate out of the container.
4. Open the loading window.
5. Place the adjustment aid for large substrates on the chuck.

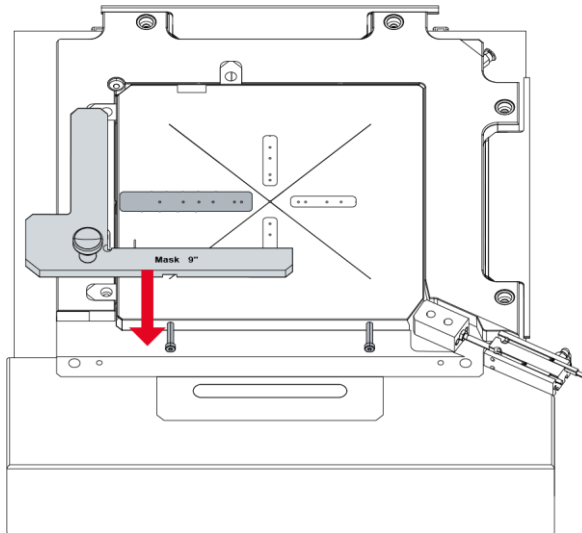

Fig. 62: Place the adjustment aid for large substrates

6. Carefully place the substrate correctly oriented on the chuck and align the substrate with the left edge and the lower edge of the adjustment aid.

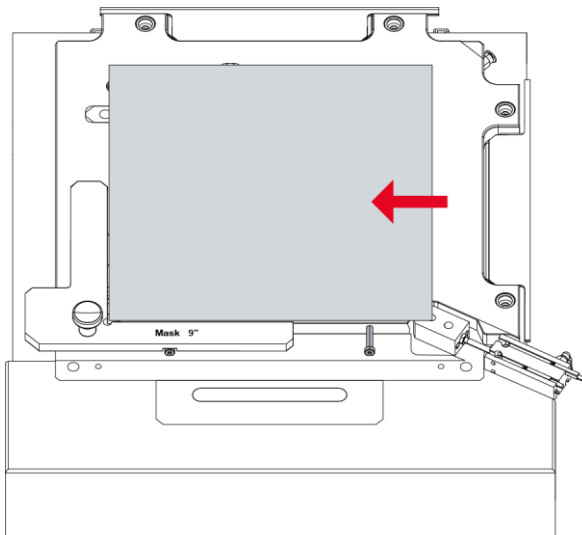

Fig. 63: Align the substrate

7. Press the **Push** button at the operator panel to switch on the vacuum.
8. Remove the adjustment aid from the chuck.

To prevent damage of the system, the system blocks the stage movement if the adjustment aid is still on the chuck.

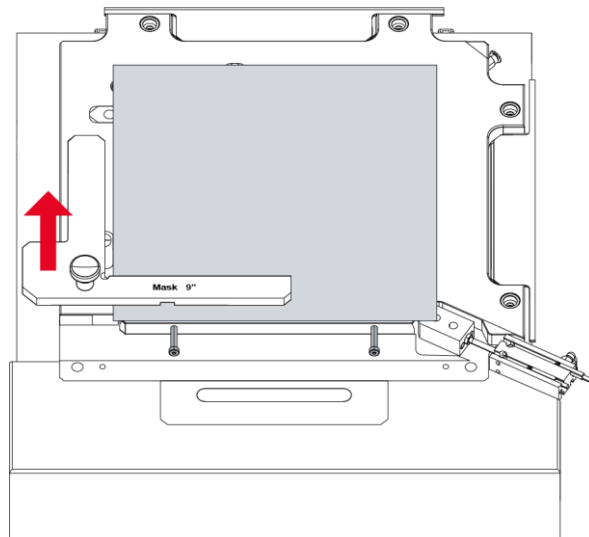

Fig. 64: Remove the adjustment aid.

9. Make sure that the substrate is held firmly in place.
- ✓ When you gently try to push the substrate sideways, the substrate does not move.

Troubleshooting if the substrate moves:

- Check the stage and the substrate for dirt.
- Check the substrate for scratches.
- Try using a different substrate.

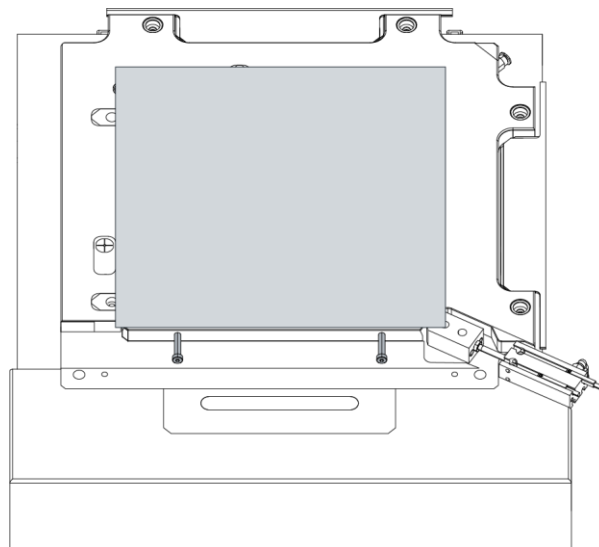

Fig. 65: Correctly aligned substrate

10. Close the loading window.

▲ CAUTION

Pinch point and shearing hazard.

Injury could result if body parts become caught in a closing window.

Keep body parts away from a closing window.

Now, the loading process is complete. Continue with the instruction for the operation that you want to perform.

7.2 Unload substrates

If you want to start another exposure job with the same substrate, skip the following steps and continue with preparing the exposure job.

Perform the following steps to unload the substrate:

1. Make sure that the stage is in the loading position.
 - If you selected **Auto-Unload** before the exposure started, the stage moves automatically into the loading position. In the control software, a dialog box opens. For more information about the **Auto-Unload** option, see "4 User interface", page 30.
 - If the stage is not in the loading position, return to the *Setup Job* frame and click **Unload** in the *Proceed* frame.
2. If a dialog box opens in the control software, follow the instructions in the dialog box that you see on the screen.
3. Open the loading window.
4. Press the **Push** button at the operator panel to turn off the vacuum.
5. Remove the substrate from the chuck.
6. Close the loading window.

CAUTION

Pinch point and shearing hazard.

Injury could result if body parts become caught in a closing window.

Keep body parts away from a closing window.

Now, you can continue with preparing another exposure job.

7.3 Exchange chucks

The chuck is fixed by a pneumatic clamp. The chuck is exchangeable on demand to meet the requirements of your application.

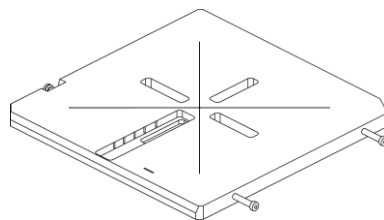

Fig. 66: Standard chuck

Perform the following steps to exchange the chuck:

1. Open the loading window.
2. If the vacuum is turned on, press the **Push** button at the operator panel to turn off the vacuum.

3. Switch the pneumatic clamp switch behind the operator panel.

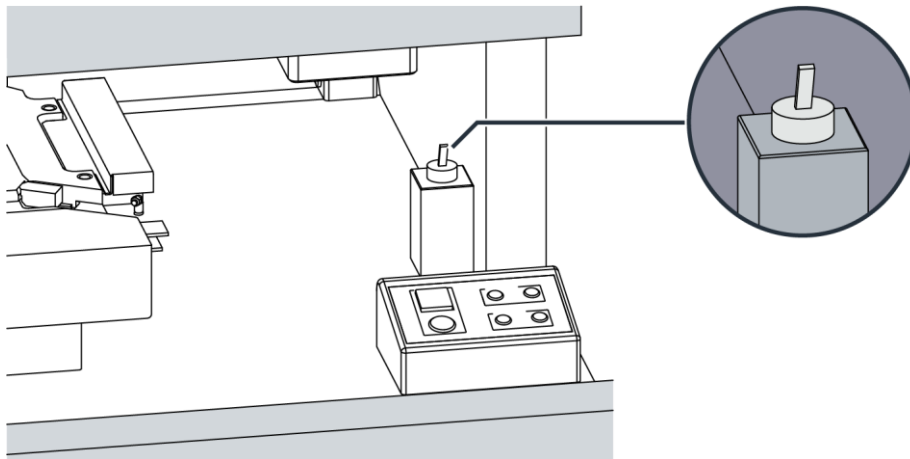

Fig. 67: Pneumatic clamp switch

- ✓ The pneumatic clamp, which fixates the chuck, opens.

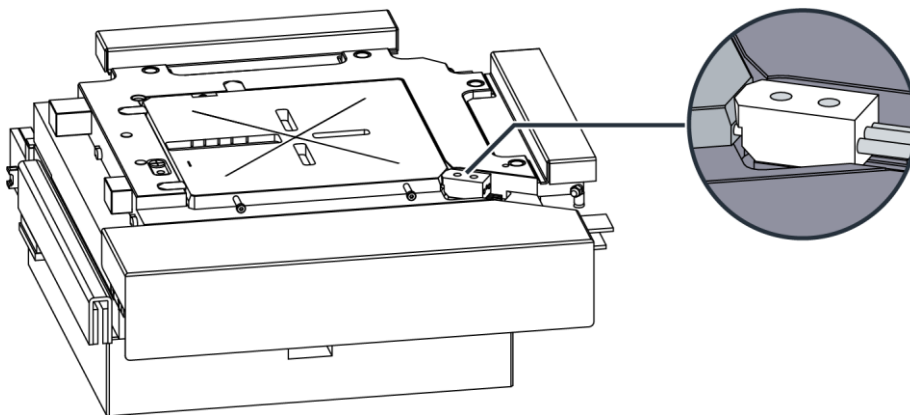

Fig. 68: Pneumatic clamp

4. If a substrate is on the chuck, remove the substrate from the chuck.
5. Carefully remove the chuck from the frame.

NOTICE

Risk of damage

Risk of damage to the interferometer mirrors.
Do not touch the interferometer mirrors.

6. Place the new chuck in the frame.

CAUTION

Pinch point hazard

Risk of minor injury if fingers get caught between the pneumatic clamp and the chuck.
Keep fingers away from the pneumatic clamp.

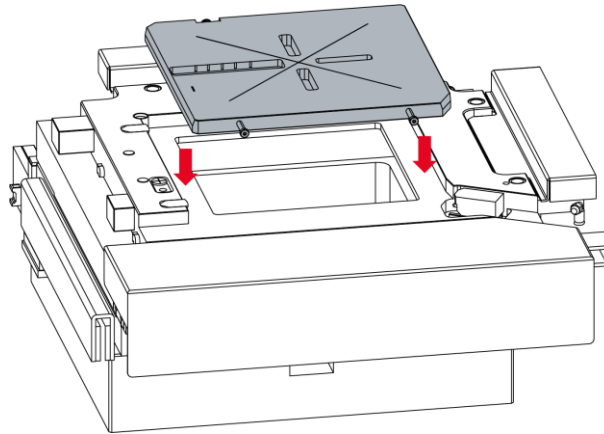

Fig. 69: Place the chuck in the frame

7. Switch the pneumatic clamp switch behind the operator panel.
 - ✓ The pneumatic clamp, which fixates the chuck, closes.
 - ✓ The chuck exchange is completed.
8. If you want to check the vacuum, continue with the following steps:
 1. Place a substrate on the chuck.
 2. Turn on the vacuum.
 3. At the operator panel, check the measured pressure to make sure that the vacuum connectors make a good seal.
9. Close the loading window.

⚠ CAUTION

Pinch point and shearing hazard.

Injury could result if body parts become caught in a closing window.

Keep body parts away from a closing window.

Now, the chuck is ready for operation.

8 Execute exposures

The exposure quality depends on several factors. For example, the resist that you use can affect the exposure quality. To find out the best settings for your application, you can execute an exposure series. With the exposure series, you can test different light intensities and focus offsets to determine the settings that give the best exposure results for your application. For more information, see "8.4 Execute exposure series", page 130.

8.1 Execute single-layer exposures

The following procedure explains how to execute single-layer exposures.

8.1.1 SET UP JOBS

Note that the following instruction may contain steps related to features, options, or objects that are not available for your system. Skip the steps that are not relevant for you.

Perform the following steps to set up a single-layer exposure job:

1. Create or load a job.
 - For more information about creating a job, see "6.3 Create jobs", page 77.
If you create a new job, you must set all required parameters. The steps below explain how to set the required parameters.
 - For more information about loading a job, see "6.4 Load jobs", page 78.
If you load an existing job, you do not need to set all parameters again, but you must carefully check all parameters for correctness and completeness. The steps below support you with the evaluation of the parameters.
2. Select **Standard** from the **Exposure Mode** drop-down list in the *Job* frame of the *Setup Job* frame.
 - ✓ You see the *Layer* frame in the *Setup Job* frame.
 - ✓ You see **FirstExposure** in the field below **Layer** in the *Layers* table.
3. Double-click the field below **Substrate Template** in the *Substrate* frame.
 - ✓ The *Load Substrate* frame opens.
4. Select the substrate template that you want to use from the *Substrate Templates* table.
If you do not want to use a substrate template, set the parameters of the substrate that you want to use in the *Characteristics* frame and, if required, in the *Advanced Parameters* frame.
5. Click **Load** in the *Load* frame to confirm.
 - ✓ The *Setup Job* frame opens.
 - ✓ You see the parameters of the substrate in the *Substrate* frame.

6. Click the field below **Laser** in the *Layer* frame and select the laser that you want to use from the drop-down list.
7. Click the field below **Laser Power** in the *Layer* frame and select the light intensity that you want to use from the drop-down list.
8. Click the field below **Focus Mode** in the *Layer* frame and select the focus mode that you want to use from the drop-down list.
9. Double-click the field below **Design** in the *Layer* frame.
 - ✓ The *Load Design* frame opens.
10. Select the design that you want to use from the *Designs* table.
11. Click **Load** in the *Load* frame to confirm.
 - ✓ The *Setup Job* frame opens.
 - ✓ You see the name of the design in the field below **Design** in the *Layer* frame.
12. If you want to expose alignment marks or other bitmaps, double-click the field below **Exposure Bitmaps** in the *Layer* frame.
 - ✓ The *Load Exposure Bitmaps* frame opens.
13. Select the bitmap template that you want to use from the *Bitmap Templates* table.
14. Click **Load** in the *Load* frame to confirm.
 - ✓ The *Setup Job* frame opens.
 - ✓ You see the name of the bitmap template in the field below **Exposure Bitmaps** in the *Layer* frame.
15. If you selected a grayscale design or if you want to set the resist thickness, double-click the field below **Resist** in the *Layer* frame.

If you expose a grayscale design, this step is mandatory. Else, this step is optional.

 - ✓ The *Load Resist* frame opens.
16. Select the resist template that you want to use from the *Resists* table.
17. Click **Load** in the *Load* frame to confirm.
 - ✓ The *Setup Job* frame opens.
 - ✓ You see the name of the resist template in the field below **Resist** in the *Layer* frame.
18. If you want to activate the high aspect ratio mode, click the field below **HAR** in the *Layer* frame and select the high aspect ratio mode that you want to use from the drop-down list.
19. If you want to save the job with the current parameters, click **Save Job** in the *Job* frame.

Now, the setup of the job is completed. Continue with the steps below.

8.1.2 LOAD SUBSTRATES

Note that the following instruction may contain steps related to features, options, or objects that are not available for your system. Skip the steps that are not relevant for you.

Perform the following steps to load a substrate:

1. Choose one of the following options:

- If the substrate that you want to use is not yet loaded, click **Load Substrate** in the *Proceed* frame.

✓ The stage moves into the loading position.

Continue with loading a substrate onto the chuck. For more information, see "7.1 Load substrates", page 80.

- If the substrate that you want to use is already loaded, click **First Exposure** in the *Proceed* frame.

✓ The *First Exposure* frame opens.

Continue with setting up the exposure parameters. For more information, see "8.1.3 Set up exposure parameters", page 93.

2. When the substrate is successfully loaded onto the chuck, click **Continue** in the *Proceed* frame.

✓ The system measures the loaded substrate.

Troubleshooting:

If the substrate size was not completely defined, a dialog box opens and asks how to proceed. Select one of the available options to solve the issue.

3. Make sure that the substrate is located under the write head.

Troubleshooting:

If the substrate is not located under the write head, click **Cancel** in the *Proceed* frame. Then, restart the loading procedure to solve the issue.

4. Click **Continue** in the *Proceed* frame.

✓ The system starts a find plate center procedure to detect the center of the substrate.

Troubleshooting if the system cannot detect the center of the substrate or if the system does not detect the center of the substrate correctly:

- Manually determine the center and rotation of the substrate.

For more information, see "8.6 Find substrate centers", page 143.

✓ You see information about the progress status on the screen.

✓ When the procedure is successfully completed, the *First Exposure* frame opens.

Now, the loading procedure is completed. Continue with the steps below.

8.1.3 SET UP EXPOSURE PARAMETERS

Note that the following instruction may contain steps related to features, options, or objects that are not available for your system. Skip the steps that are not relevant for you.

Perform the following steps to set up the exposure parameters:

1. Make sure that the correct design is set in the **Design Name** field.
2. Make sure that the correct wavelength is set for the laser in the **Laser** field.
3. Make sure that the correct light intensity is set in the **Laser Power** field.
4. Make sure that the correct high aspect ratio mode is set in the **High Aspect Ratio** field.
5. Make sure that the correct autofocus mode is selected from the **Focus Mode** drop-down list.
6. Set the dose in the **Dose** field.
7. Set the focus offset in the **Defoc** field.
8. If you want to rotate the design by the substrate angle, select **Expose with Substrate Angle**.

The substrate angle represents the rotation of the substrate on the chuck. The system measured the substrate angle during the find center procedure. The design is rotated by substrate angle to compensate the substrate rotation.

The substrate angle is particularly relevant for small substrates, which are usually difficult to load perfectly straight.

9. If you selected a grayscale design, select **Set individual Doses for each Bitlayer**.
This option is only available if you selected a design that is applicable for grayscale exposure.
Set the individual doses for the bit layers in the table below the checkbox.
10. If you selected bitmaps to expose during the job setup, select **Expose the Bitmaps** to activate the exposure of the bitmaps.
 - ✓ You see a table that shows the positions of the bitmaps below the checkbox.
 - Click **Edit** to edit the values in the table.
 - Click **Original** to reset the values in the table.

If you expose bitmaps, selecting also **Expose with Substrate Angle** is recommended.
11. If you want to set a waiting time before the exposure starts, select **Delay Exposure** and set the time.

12. If you want to automatically unload the substrate when the exposure is completed, select **Auto-Unload the Substrate**.
 - If you want to remove the substrate from the chuck for further processing after the exposure, select this option. Then, the unloading procedure starts automatically after the exposure is completed.
 - If you want to keep the substrate on the chuck after the exposure, deselect this option. Then, the system asks you if you want to unload when the exposure is completed.
13. If you want to add a comment, enter the comment in the **Comment** field.

Now, the setup of the exposure parameters is completed. Continue with the steps below.

8.1.4 EXECUTE EXPOSURES

Perform the following steps to execute the exposure:

1. Click **Start Exposure** in the *Proceed* frame.
 - ✓ The system performs an online conversion of the design.
 - ✓ The exposure starts.
 - ✓ You see information about the exposure progress in the *Progress Info* frame.
 - ✓ If **Auto-Unload Substrate** is deselected, the *Exposure Finished* dialog box opens.
2. If the *Exposure Finished* dialog box opens, choose if you want to unload the substrate:
 - **Yes**: Start the unloading procedure.
Continue with unloading the substrate. For more information, see "7.2 Unload substrates", page 87.
 - **No**: Keep the substrate loaded, for example, to expose another layer on the same substrate.
- ✓ The *Setup Job* frame opens.

Now, the procedure is completed. Continue with one of the following options:

- If you want to save the job with the current parameters and settings, click **Save Job** in the *Job* frame.
- If you want to repeat the job, click **Repeat Job** in the *Job* frame.
- If you want to start another operation, follow the instructions for the operation that you want to perform.

8.2 Execute multi-layer exposures

The following procedure explains how to execute multi-layer exposures.

Multi-layer exposures, also referred to as overlay exposures, describe the process of exposing designs in several layers on above another.

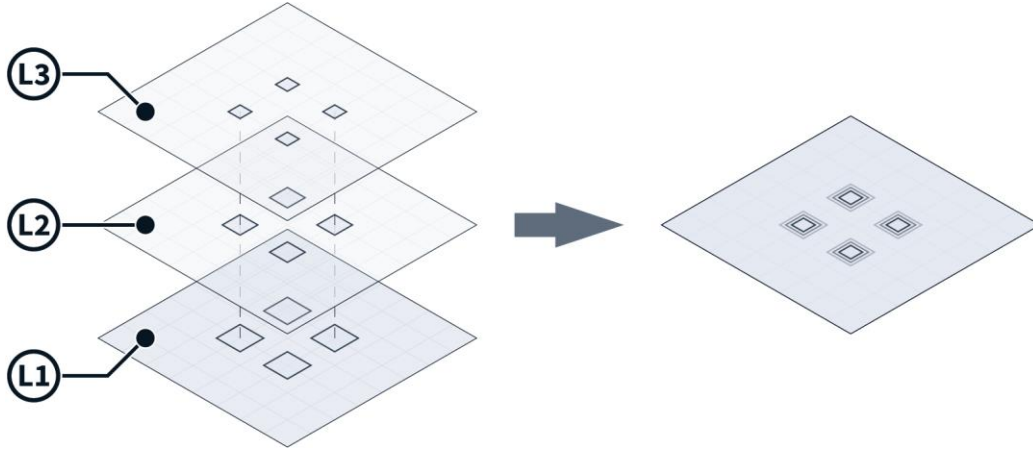

Fig. 70: Multi-layer exposure

In multi-layer exposures, each layer is exposed individually. After the exposure of a layer, the substrate is processed according to the requirements of the respective application and prepared for the exposure of the next layer.

In the *Layer* frame of the *Setup Job* frame, the first layer is the First Exposure layer, which is represented by the first row in the *Layer* table. The First Exposure layer is added automatically when you set up a standard exposure job. Every additional row that you add to the *Layer* table represents a subsequent layer. The subsequent layers are Alignment layers. Alignment layers are the layers that can be aligned with the previously exposed alignment marks.

Multi-layer exposures, also referred to as overlay exposures, describe the process of exposing designs in several layers on above another.

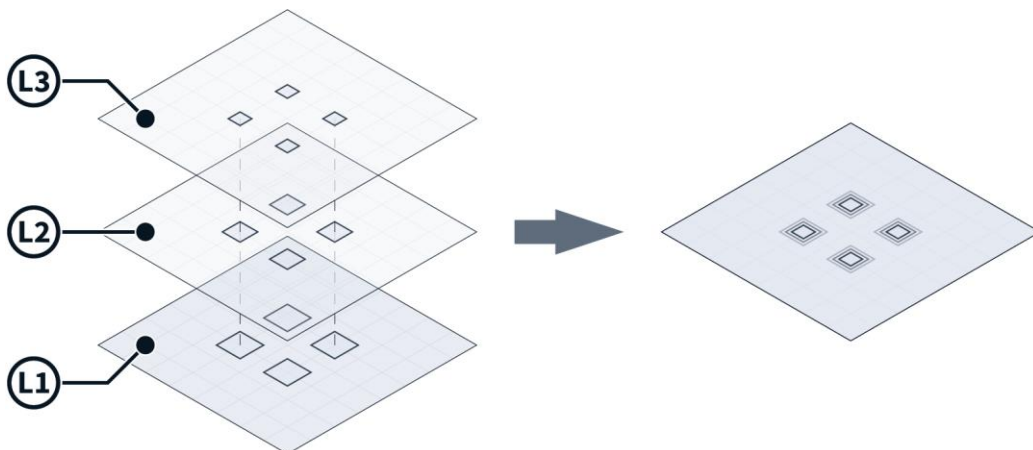

Fig. 71: Multi-layer exposure

In multi-layer exposures, each layer is exposed individually. After the exposure of a layer, the substrate is processed according to the requirements of the respective application and prepared for the exposure of the next layer.

ALIGNMENT

Between the exposure of two layers, the previous layer must be aligned with the next. The alignment ensures that the structures of the different layers are positioned correctly. You use alignment marks for alignment. Alignment marks are reference structures used to determine the exact position and rotation of the substrate.

During the alignment process, the alignment mark is centered in the camera image. If the center of the alignment mark is directly in the center of the camera image, the alignment mark is measured. The system shifts and rotates the machine coordinate system based on the measurement results so that the coordinate system of the previous layer and the following layer match.

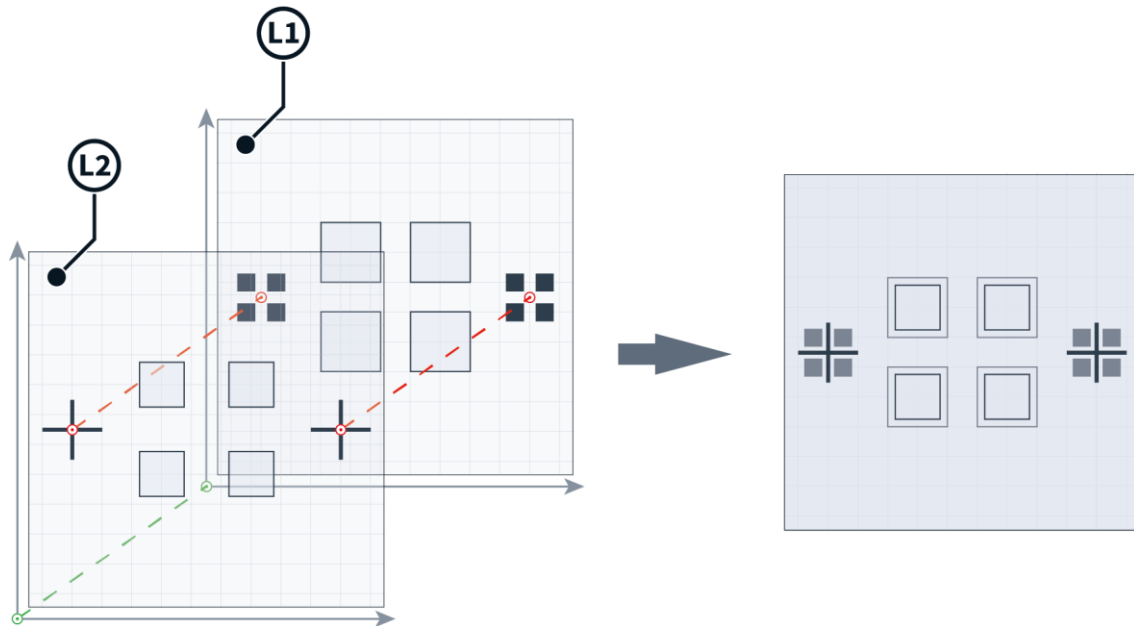

Fig. 72: Alignment of multiple layers

ALIGNMENT MARKS

The first layer you expose should contain the first set of alignment marks. When you align the second layer, the camera image is centered on the alignment marks of the previous layer in sequence. This procedure must be repeated for every layer.

Careful planning of the alignment marks is important. For alignment to be accurate, the alignment marks must be clearly visible on the substrate with sufficient contrast. Make sure the alignment marks are large enough so that they can be easily located. You can add smaller marks or lines to guide you to the alignment marks. You can also mark the alignment marks with labels for identification. It may also be helpful to attach a direction indicator to verify that the substrate is properly aligned on the table.

To better check the alignment of the exposed layers, you can use alignment marks that only touch at the corners when correctly aligned. Then you can evaluate the alignment quality based on the gap dimensions.

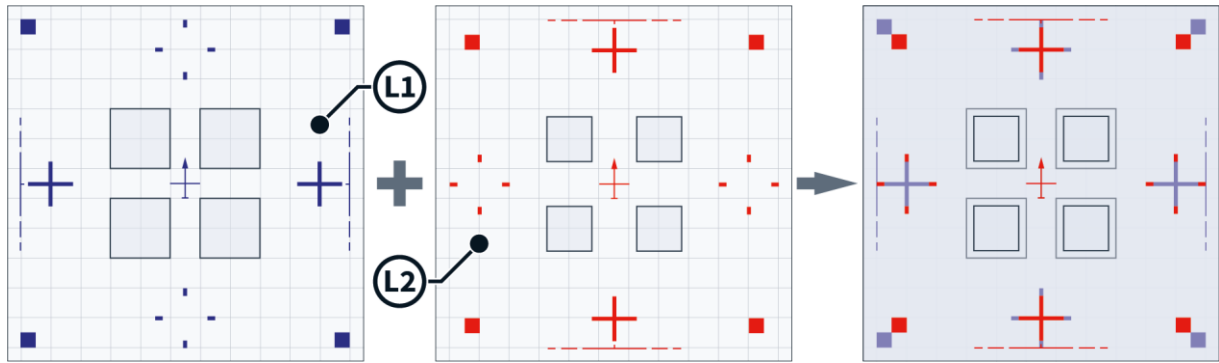

Fig. 73: Example of alignment mark design and placement

For frontside alignment, each layer you expose should contain a set of alignment marks, as the visibility of alignment marks can be degraded by substrate processing and additional applied resist layers.

BACKSIDE ALIGNMENT
NOTE

This section may contain information about features, options, or objects that are not available for your system.

For information about your system specification, see the Technical Datasheet.

If your system supports backside alignment, you can expose alignment marks on the lower surface of the substrate instead of the upper surface, which is the exposure side. Backside alignment can provide images with more contrast in cases where layers of resist or other materials on the upper surface might impact the detection of the alignment marks.

On the first layer, you expose only the alignment marks. For the exposure of all further layers, you turn the substrate so that the exposed alignment marks are at the lower surface. Then, you can use the backside camera underneath the stage to find and center the alignment marks.

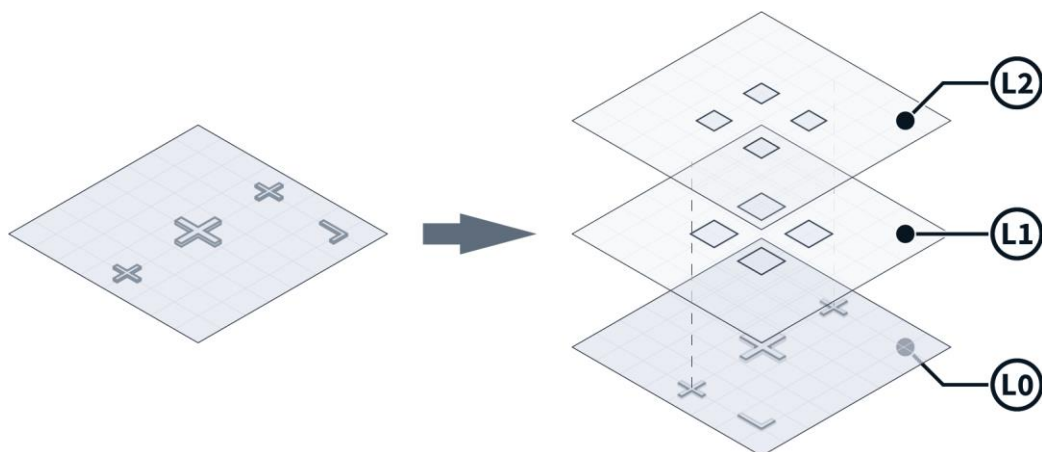

Fig. 74: Backside alignment marks on the lower surface

When you perform a backside alignment, note that coordinates always refer to the substrate side that is currently the upper surface. So, an alignment mark that is exposed on the right side will be on the left side when you turn around the substrate. This means,

if an alignment mark is exposed at position [X: +20 mm], the alignment mark will be at position [X: -20 mm] for the backside alignment.

The chuck for backside alignment has designated openings through which the backside camera can detect alignment marks on the lower surface of the substrate. The alignment marks on the lower surface must be within the area of the openings for the backside camera to be able to detect the alignment marks.

If your system supports infrared backside alignment, an infrared source, emits infrared radiation from above the stage onto the chuck. The infrared radiation permeates both the existing layers and the substrate and is then reflected by the material of the chuck. The infrared camera, which is also installed above the stage, captures the reflected radiation and generates an image to the alignment marks at the lower surface of the substrate.

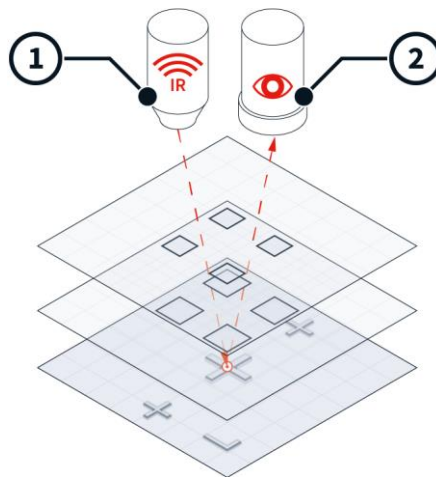

Fig. 75: Infrared backside alignment with alignment marks on the upper surface

- 1 Infrared source
- 2 Infrared camera

GLOBAL ALIGNMENT

To detect the rotation of the substrate on the chuck, you perform global alignments. The system shifts and rotates the machine coordinate system based on the measurement results of the global alignments.

In global alignment, two or more previously defined points are measured. The coordinates of the points indicate the position of the substrate on the chuck and, thus, the origin of the coordinate system on the substrate. The line connecting the points shows where the axes of the coordinate system are located on the substrate. The system shifts and rotates the machine coordinate system accordingly.

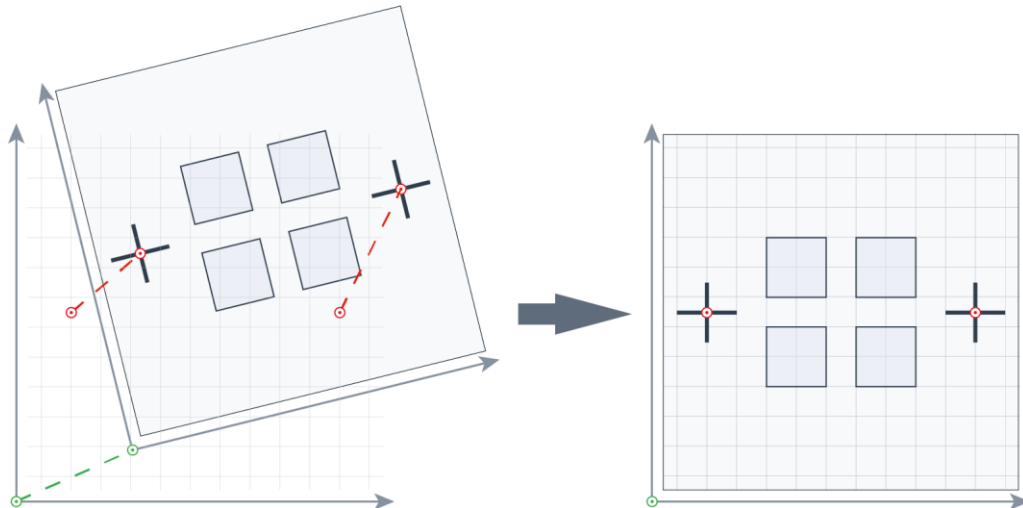

Fig. 76: Global alignment

For more precise measurement results, measure at least 4 points or to perform two global alignments with 2 measuring points each. The greater the distance between 2 measuring points, the more accurate the measurement results.

FIELD ALIGNMENT NOTE

This section may contain information about features, options, or objects that are not available for your system.

For information about your system specification, see the Technical Datasheet.

If your system supports field alignment, you can additionally perform an alignment for each field (*die*). Field alignment determines the origin of the local coordinate system in the field for fine adjustment of angle and scaling.

In field-aligned exposures, additional alignment marks are exposed in each field. Then, the fields of subsequent layers are individually aligned to the field alignment marks of the previous layer.

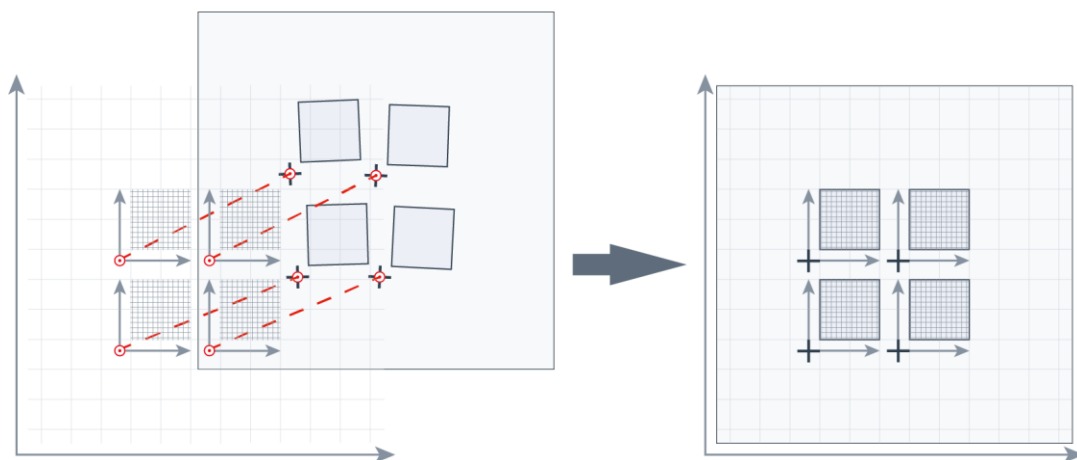

Fig. 77: Field alignment

To avoid unwanted overlaps or joins, plan the fields large enough so that you can place the field alignment marks a sufficient distance from the patterns to be exposed.

CALIBRATION

Alignments are optical measurements with the camera. Because the center of the camera image and the write beam do not point to the same point on the substrate, the system must know the exact position of the write beam relative to the center of the camera image.

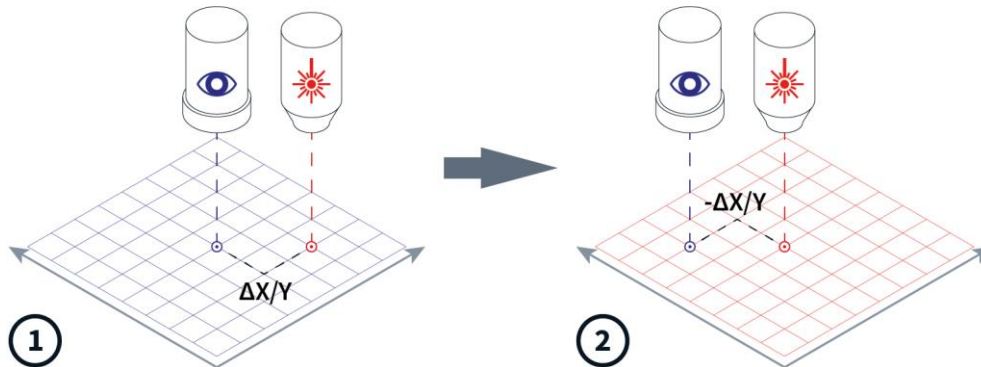

Fig. 78: Global alignment

- 1 Camera coordinate system
- 2 Machine coordinate system

To determine the position of the write beam relative to the center of the camera image, you must calibrate the offset of the camera with respect to the write beam. In addition, you must calibrate each individual camera if your system has multiple cameras. First, calibrate a reference camera with respect to the write beam. Then, calibrate the other cameras with respect to the reference camera.

It is not necessary to calibrate before each exposure. However, if shifts occur between exposed layers, it is advisable to calibrate the cameras because the position of the write beam and the camera may change slightly over time. If the write head is replaced, calibration is necessary.

For more information, see "10 Execute calibrations", page 158.

If you use the mirror or rotation function when importing a design in the conversion software, note that you need to update all layers so that the settings are applied to all layers of the design.

For more information, see *Conversion Software Guide*.

The instructions consider the settings for global alignment. If you need more information about field alignment, which uses an alignment mark in each exposed field, see "8.3 Execute field-aligned exposures", page 114 for additional instructions.

8.2.1 SET UP JOBS

Note that the following instruction may contain steps related to features, options, or objects that are not available for your system. Skip the steps that are not relevant for you.

Perform the following steps to set up the first layer:

1. Create or load a job.
 - For more information about creating a job, see "6.3 Create jobs", page 77.
If you create a new job, you must set all required parameters. The steps below explain how to set the required parameters.
 - For more information about loading a job, see "6.4 Load jobs", page 78.
If you load an existing job, you do not need to set all parameters again, but you must carefully check all parameters for correctness and completeness. The steps below support you with the evaluation of the parameters.
2. Select **Standard** from the **Exposure Mode** drop-down list in the *Job* frame of the *Setup Job* frame.
 - ✓ You see the *Layer* frame in the *Setup Job* frame.
 - ✓ You see **FirstExposure** in the field below **Layer** in the *Layers* table.
The **FirstExposure** row is for the definition and exposure of the alignment marks that you use for the exposure of the subsequent layers.
3. Double-click the field below **Substrate Template** of the *Substrate* frame.
 - ✓ The *Load Substrate* frame opens.
4. Select the substrate template that you want to use from the *Substrate Templates* table.
If you do not want to use a substrate template, set the parameters of the substrate that you want to use in the *Characteristics* frame and, if required, in the *Advanced Parameters* frame.
5. Click **Load** in the *Load* frame to confirm.
 - ✓ The *Setup Job* frame opens.
 - ✓ You see the parameters of the substrate in the *Substrate* frame.
6. Click the field below **Laser** in the **FirstExposure** row of the *Layer* frame and select the laser that you want to use from the drop-down list.
7. Click the field below **Laser Power** in the **FirstExposure** row of the *Layer* frame and select the light intensity that you want to use from the drop-down list.
8. Click the field below **Focus Mode** in the **FirstExposure** row of the *Layer* frame and select the focus mode that you want to use from the drop-down list.
9. Double-click the field below **Design** in the **FirstExposure** row of the *Layer* frame.
 - ✓ The *Load Design* frame opens.
10. Select the design that you want to expose on the first layer from the *Designs* table.

11. Click **Load** in the *Load* frame to confirm.
 - ✓ The *Setup Job* frame opens.
 - ✓ You see the name of the design in the field below **Design** in the **FirstExposure** row of the *Layer* frame.
12. Double-click the field below **Exposure Bitmaps** in the **FirstExposure** row of the *Layer* frame to set up the alignment marks that you want to expose.
 - ✓ The *Load Exposure Bitmaps* frame opens.
13. Select the bitmap template that you want to use from the *Bitmap Templates* table.
14. Click **Load** in the *Load* frame to confirm.
 - ✓ The *Setup Job* frame opens.
 - ✓ You see the name of the bitmap template in the field below **Exposure Bitmaps** in the **FirstExposure** row of the *Layer* frame.
15. If you selected a grayscale design or if you want to set the resist thickness, double-click the field below **Resist** in the in the **FirstExposure** row of the *Layer* frame.

If you expose a grayscale design, this step is mandatory. Else, this step is optional.

 - ✓ The *Load Resist* frame opens.
16. Select the resist template that you want to use from the *Resists* table.
17. Click **Load** in the *Load* frame to confirm.
 - ✓ The *Setup Job* frame opens.
 - ✓ You see the name of the resist in the field below **Resist** in the **FirstExposure** row of the *Layer* frame.
18. If you want to activate the high aspect ratio mode, click the field below **HAR** in the **FirstExposure** row of the *Layer* frame and select the high aspect ratio mode that you want to use from the drop-down list.
19. If you want to save the job with the current parameters, click **Save Job** in the *Job* frame.

Now, the setup of the first layer is completed. Continue with the steps below.

8.2.2 LOAD SUBSTRATES

Note that the following instruction may contain steps related to features, options, or objects that are not available for your system. Skip the steps that are not relevant for you.

Perform the following steps to load a substrate:

1. Choose one of the following options:
 - If the substrate that you want to use is not yet loaded, click **Load Substrate** in the *Proceed* frame.
 - ✓ The stage moves into the loading position.

Continue with loading a substrate onto the chuck. For more information, see "7.1 Load substrates", page 80.

- If the substrate that you want to use is already loaded, click **First Exposure** in the *Proceed* frame.
 - ✓ The *First Exposure* frame opens.
Continue with setting up the exposure parameters. For more information, see "8.2.7 Set up global alignment parameters", page 107.
2. When the substrate is successfully loaded onto the chuck, click **Continue** in the *Proceed* frame.
 - ✓ The system measures the loaded substrate.
Troubleshooting:
If the substrate size was not completely defined, a dialog box opens and asks how to proceed. Select one of the available options to solve the issue.
 3. Make sure that the substrate is located under the write head.
 - Troubleshooting:
If the substrate is not located under the write head, click **Cancel** in the *Proceed* frame. Then, restart the loading procedure to solve the issue.
 4. Click **Continue** in the *Proceed* frame.
 - ✓ The system starts a find plate center procedure to detect the center of the substrate.
Troubleshooting if the system cannot detect the center of the substrate or if the system does not detect the center of the substrate correctly:
 - Manually determine the center and rotation of the substrate.
For more information, see "8.6 Find substrate centers", page 143.

You see information about the progress status on the screen.

- ✓ When the procedure is successfully completed, the *First Exposure* frame opens.
Now, the loading procedure is completed. Continue with the steps below.

8.2.3 SET UP EXPOSURE PARAMETERS

Note that the following instruction may contain steps related to features, options, or objects that are not available for your system. Skip the steps that are not relevant for you.

Perform the following steps to set up the exposure parameters for the first layer:

1. Make sure that the correct design is set in the **Design Name** field.
2. Make sure that the correct wavelength is set for the laser in the **Laser** field.
3. Make sure that the correct light intensity is set in the **Laser Power** field.
4. Make sure that the correct high aspect ratio mode is set in the **High Aspect Ratio** field.
5. Make sure that the correct autofocus mode is selected from the **Focus Mode** drop-down list.
6. Set the dose in the **Dose** field.
7. Set the focus offset in the **Defoc** field.

8. If you want to rotate the design by the substrate angle, select **Expose with Substrate Angle**.

The substrate angle represents the rotation of the substrate on the chuck. The system measured the substrate angle during the find center procedure. The design is rotated by the substrate angle to compensate the substrate rotation.

The substrate angle is particularly relevant for small substrates, which are usually difficult to load perfectly straight.

9. If you selected a grayscale design, select **Set individual Doses for each Bitlayer**.

This option is only available if you selected a design that is applicable for grayscale exposure.

Set the individual doses for the bit layers in the table below the checkbox.

10. If you selected bitmaps to expose during the job setup, select **Expose the Bitmaps** to activate the exposure of the bitmaps.

- ✓ You see a table that shows the positions of the bitmaps below the checkbox.

- Click **Edit** to edit the values in the table.
- Click **Original** to reset the values in the table.

If you expose bitmaps, selecting also **Expose with Substrate Angle** is recommended.

- ✓ The setup of the alignment marks is completed.

11. If you want to set a waiting time before the exposure starts, select **Delay Exposure** and set the time.

12. If you want to automatically unload the substrate when the exposure is completed, select **Auto-Unload the Substrate**.

- If you want to remove the substrate from the chuck for further processing after the exposure, select this option. Then, the unloading procedure starts automatically after the exposure is completed.
- If you want to keep the substrate on the chuck after the exposure, deselect this option. Then, the system asks you if you want to unload when the exposure is completed.

13. If you want to add a comment, enter the comment in the **Comment** field.

Now, the setup of the exposure parameters is completed. Continue with the steps below.

8.2.4 EXECUTE EXPOSURES

Perform the following steps to execute the exposure:

1. Click **Start Exposure** in the *Proceed* frame.

- ✓ The system performs an online conversion of the design.
- ✓ The exposure starts.
- ✓ You see information about the exposure progress in the *Progress Info* frame.
- ✓ If **Auto-Unload Substrate** is deselected, the *Exposure Finished* dialog box opens.

2. If the *Exposure Finished* dialog box opens, choose if you want to unload the substrate:
 - **Yes:** Start the unloading procedure.
Continue with unloading the substrate. For more information, see "7.2 Unload substrates", page 87.
 - **No:** Skip the unloading procedure and keep the substrate on the chuck.
- ✓ The *Setup Job* frame opens.

Now, the exposure of the first layer with the alignment marks is completed. Continue with the steps below.

8.2.5 SET UP LAYERS

Perform the following steps to set up another layer:

1. Click **Add Layer** below at the bottom of the *Layer* frame to add another layer.
- ✓ Another row is added to the *Layers* table. The layer represents the subsequent layer in the exposure.
2. Click the field below **Laser** in the relevant row of the *Layer* frame and select the laser that you want to use from the drop-down list.
3. Click the field below **Laser Power** in the relevant row of the *Layer* frame and select the light intensity that you want to use from the drop-down list.
4. Click the field below **Focus Mode** in the relevant row of the *Layer* frame and select the focus mode that you want to use from the drop-down list.
5. Double-click the field below **Design** in the relevant row of the *Layer* frame.
- ✓ The *Load Design* frame opens.
6. Select the design that you want to expose on the first layer from the *Designs* table.
7. Click **Load** in the *Load* frame to confirm.
- ✓ The *Setup Job* frame opens.
- ✓ You see the name of the design in the field below **Design** in the relevant row of the *Layer* frame.
8. If you want to expose additional alignment marks or other bitmaps, double-click the field below **Exposure Bitmaps** in the relevant row of the *Layer* frame to set up the alignment marks or bitmaps that you want to expose.
- ✓ The *Load Exposure Bitmaps* frame opens.
9. Select the bitmap template that you want to use from the *Bitmap Templates* table.
10. Click **Load** in the *Load* frame to confirm.
- ✓ The *Setup Job* frame opens.
- ✓ You see the name of the bitmap template in the field below **Exposure Bitmaps** in the relevant row of the *Layer* frame.
11. Double-click the field below **Alignment Settings** in the relevant row of the *Layers* frame.
- ✓ The *Load Alignment Settings* frame opens.

12. Select the alignment template that you want to use from the *Alignments* table.

If you want to manually set the positions of the alignment marks later, select the *_Manual* alignment template. After the exposure is completed, the positions of the manually set alignment marks will be save as a new alignment template. The file name of the alignment template will be <jobname>_AlignPos_L<layer-number>.

- ✓ You see the alignment parameters of the selected alignment template in the *Alignment Settings* frame.
13. If you want to change the alignment parameters, click **Edit** next to the table that shows the coordinates of the alignment marks in the *Alignment Settings* frame.
- Adjust the alignment parameters to meet the requirements of your application.
14. Click **Load** in the *Load* frame to confirm.
- ✓ The *Setup Job* frame opens.
 - ✓ You see the name of the alignment template in the field below **Alignment Settings** in the relevant row of the *Layer* frame.
 - ✓ You see the coordinates of the alignment marks in the *Alignment Info* frame.
15. If you want to save the job with the current parameters, click **Save Job** in the *Job* frame.

Now, the setup of the layer is completed. Continue with the steps below.

8.2.6 LOAD SUBSTRATES

Note that the following instruction may contain steps related to features, options, or objects that are not available for your system. Skip the steps that are not relevant for you.

Perform the following steps to load a substrate:

1. Choose one of the following options:
 - If the substrate that you want to use is not yet loaded, click **Load Substrate** in the *Proceed* frame.
 - ✓ The stage moves into the loading position.
 - If the substrate that you want to use is already loaded, click **Alignment** in the *Proceed* frame.
 - ✓ The *Alignment* frame opens.

Continue with loading a substrate onto the chuck. For more information, see "7.1 Load substrates", page 80.

Continue with setting up the alignment parameters. For more information, see "8.2.3 Set up exposure parameters", page 103.
2. When the substrate is successfully loaded onto the chuck, click **Continue** in the *Proceed* frame.
 - ✓ The system measures the loaded substrate.

Troubleshooting:

If the substrate size was not completely defined, a dialog box opens and asks how to proceed. Select one of the available options to solve the issue.

3. Make sure that the substrate is located under the write head.

Troubleshooting:

If the substrate is not located under the write head, click **Cancel** in the *Proceed* frame. Then, restart the loading procedure to solve the issue.

4. Click **Continue** in the *Proceed* frame.

- ✓ The system starts a find plate center procedure to detect the center of the substrate.

Troubleshooting if the system cannot detect the center of the substrate or if the system does not detect the center of the substrate correctly:

- Manually determine the center and rotation of the substrate.

For more information, see "8.6 Find substrate centers", page 143.

You see information about the progress status on the screen.

- ✓ When the procedure is successfully completed, the *Alignment* frame opens.

Now, the loading procedure is completed. Continue with the steps below.

8.2.7 SET UP GLOBAL ALIGNMENT PARAMETERS

Note that the following instruction may contain steps related to features, options, or objects that are not available for your system. Skip the steps that are not relevant for you.

Perform the following steps to set up the global alignment parameters:

1. Make sure that the correct surface is selected in the drop-down list in the table of the *Alignment Settings* frame.

If you want to make changes, click **Edit** next to the table and select the correct surface:

- If the alignment mark is at the top surface of the substrate, select **Top Surface**.
- If the alignment mark is at the bottom surface of the substrate, select **Back Surface**.

Click **Apply** to confirm.

2. Make sure that the table in the *Alignment Settings* frame shows all relevant alignment marks with the correct coordinates.

- If you want to make changes, click **Edit** next to the table and enter the correct coordinates of the relevant alignment marks in the sequence of execution.
- If you want to reset the coordinates of the alignment marks to the presets in the alignment templates, click **Original** next to the table.

Click **Apply** to confirm.

Now, the setup of the global alignment parameters is completed. Continue with the steps below.

8.2.8 EXECUTE ALIGNMENTS

Note that the following instruction may contain steps related to features, options, or objects that are not available for your system. Skip the steps that are not relevant for you.

NOTE

The optical autofocus can react on very small differences in the substrate topography. It is possible that the optical autofocus identifies structures or irregularities on the substrate surface as alignment marks so that the automatic detection of the alignment marks is not successful.

If issues occur during the automatic detection of the alignment marks, you can align manually or select the pneumatic autofocus for the layer in the job setup.

During an alignment procedure, an existing structure is detected on the substrate. The camera view is centered on the structure. So, the center of the camera image is the reference point for the alignment and, later, the exposure.

Perform the following steps to execute the global alignment:

1. Select the alignment mode that you want to use from the **Alignment Mode** drop-down list in the *Cross Measurement* frame.
 - For cross-shaped alignment marks, select **CrossAlignment**.
The system will search for cross-shaped alignment marks at the given positions.
 - For rectangular alignment marks, select **RectangleAlignment**.
The system will search for rectangular alignment marks at the given positions.
 - Alternatively, you can select **ManualAlignment** if the automatic detection is not successful. Then, you can manually navigate to the alignment marks.

You can change the alignment mode for each alignment cross that you want to measure.
2. Select the camera mode that you want to use in the *Camera Control* frame:
 - For small alignment marks, click **High Res**.
The High-Resolution Camera mode shows more detail than the Low-Resolution Camera mode, but it covers a smaller area.
This option is not available for backside alignment.
 - For larger alignment marks, click **Low Res**.
The Low-Resolution Camera mode shows less detail than the High-Resolution Camera mode, but it covers a larger area.
This option is not available for backside alignment.
 - For alignment marks at the bottom surface, click **Backside**.
This option is available only for backside alignment.
 - For navigating and finding the alignment marks on the substrate, click **Overview**.

The Overview Camera mode shows much less detail than the High-Resolution Camera mode and the Low-Resolution Camera mode, but it covers a much larger area. So, the Overview Camera mode is less suitable for alignment.

Note that the alignment mark must be completely visible in the field of view of the camera.

3. If you want to take the substrate angle into account when moving to the first cross, activate the **Use Angle** checkbox.
4. Click **Move To First Cross**.
 - ✓ The camera automatically moves to the first alignment mark.
5. If the camera does not move to the first alignment mark automatically, perform the following steps:
 1. Use the visualization of the substrate in the *Substrate* frame of the *Alignment* frame to move the camera to the first alignment mark.

To move the camera, double-click the desired position in the *Substrate* frame.

 - ✓ The camera moves to the desired position.
 2. Move the camera until you see the alignment mark in the camera live view.
 3. Center the + icon of the camera live view above the alignment mark.
 - ✓ The camera live view is centered above the first alignment mark.
6. Adjust the values in the **Focus** field and in the **Brightness** field of the *Camera Control* frame until the camera live view shows the best-possible contrast.
 - ✓ The setup of the alignment marks and the camera live view are completed.
7. Click **Measure** in the *Cross Measurement* frame.
 - ✓ The system starts the measurement procedure.

If **CrossAlignment** or **RectangleAlignment** is selected, the system automatically moves to the position of the first alignment mark and you see the alignment mark in the camera live view. Skip the next step.

If **ManualAlignment** is selected, the stage must be manually moved to position of the first alignment mark to see the alignment mark in the camera live view.

8. If **ManualAlignment** is selected, manually measure the first alignment mark:
 1. Use the arrow buttons in the *Stage Control* frame to move to the stage to the position of the first alignment mark.

Note that the alignment mark must be completely visible and must completely fill the field of view of the camera.
 2. If the alignment mark is not completely visible or does not completely fill the field of view of the camera, click **ResizeDetectionArea** and resize the detection area rectangle in the camera live view.

To reset the size of the detection area, click **MaximizeDetectionArea**.
 3. In the camera list view, move the + icon to the center of the alignment mark.

4. In the center of the alignment mark, set a square frame by pressing the S key or set a circular frame by pressing the C key.
- ✓ You see the frame in the center of the alignment mark.

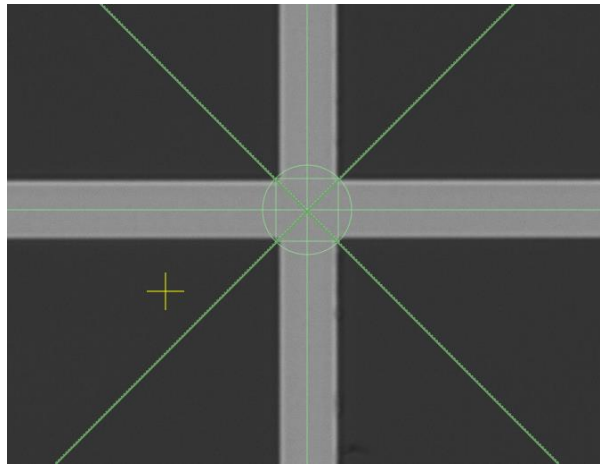

Fig. 79: Camera – Manual Alignment – Alignment center frame

If the frame is not correctly positioned, you can remove the frame by pressing the S key or the C key again.

5. Click to confirm.
- ✓ The + icon becomes orange.
6. Adjust the size of the frame by scrolling with mouse wheel.
To adjust the size in larger steps, hold the Ctrl key while scrolling with the mouse wheel.
7. Click **Center Cross** to center the camera live view to the frame.
- ✓ You see the center of the alignment mark in the camera live view.
9. If the alignment mark is the only alignment mark that you measure, adjust the value in the **Set Angle** field so that the crosshair in the camera live view exactly matches the alignment mark rotation.

This setting is helpful for small substrates that are too small for more than a single alignment mark.

For fine adjustment, you have the following options in the camera live view:

- To move the crosshair in steps of 1 pixel, use the arrow keys.
- To rotate the crosshair in steps of 1 mRad, hold the Ctrl key and use the ↑ and ↓ arrow keys.
- To rotate the crosshair in steps of 0.1 mRad, hold the Alt key and use the ↑ and ↓ arrow keys.

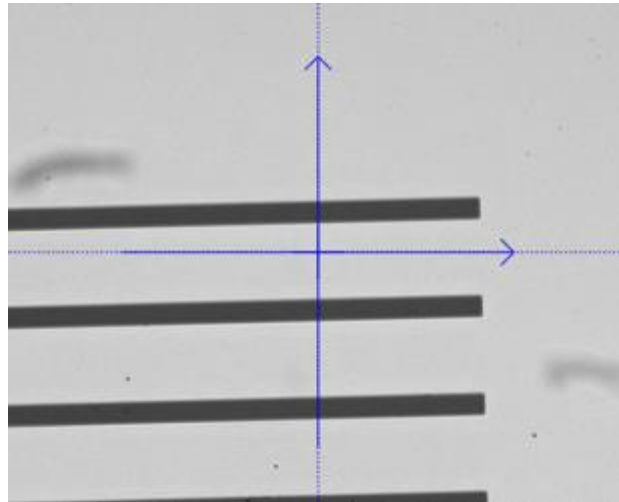

Fig. 80: Camera – Angle – Before adjustment

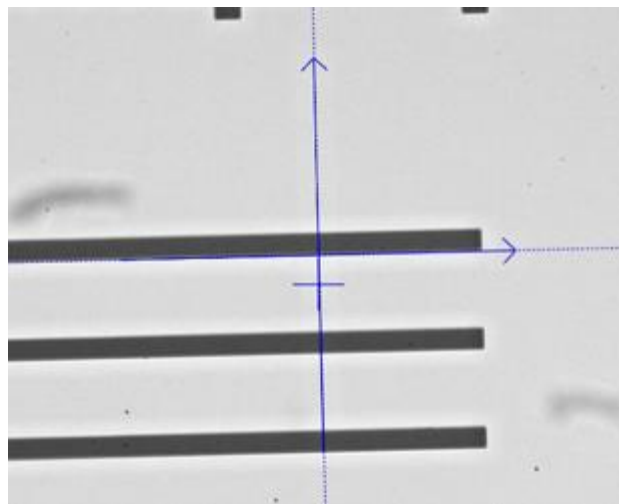



Fig. 81: Camera – Angle – After adjustment

Click  in the top right corner of the camera live view to confirm.

10. If the alignment mark is correctly displayed in the camera live view, click **Accept Position** in the *Cross Measurement* frame.

Troubleshooting if the alignment result is not correct or not satisfying:

- Click **Re-Measure** in the *Cross Measurement* frame to restart the measurement.
- If the alignment mark is not completely visible or does not completely fill the field of view of the camera, click **ResizeDetectionArea** and resize the detection area rectangle in the camera live view.

To resize the detection area rectangle, drag the corners of the rectangle.

To reset the size of the detection area, click **MaximizeDetectionArea**.

- If the system cannot detect the alignment, adjust the values in the **Focus** field and in the **Brightness** field of the *Camera Control* frame.
- If you use a very thick resist, select **Tools » Large Camera Defoc** from the menu bar to activate the extended camera offset.

To set the extended camera offset, adjust the value in the **Range** field of the *Camera Control* frame.

- ✓ The measurement of the alignment mark is completed.
- 11. Repeat the steps for every alignment mark.
- ✓ The measurement of all alignment marks is completed.
- ✓ When the procedure is successfully completed, the *Alignment Exposure* frame opens.

Now, the global alignment is completed. Continue with the steps below.

8.2.9 SET UP EXPOSURE PARAMETERS

Note that the following instruction may contain steps related to features, options, or objects that are not available for your system. Skip the steps that are not relevant for you.

Perform the following steps to set up the exposure parameters:

1. Make sure that the correct design is set in the **Design Name** field.
2. Make sure that the correct wavelength is set for the laser in the **Laser** field.
3. Make sure that the correct light intensity is set in the **Laser Power** field.
4. Make sure that the correct high aspect ratio mode is set in the **High Aspect Ratio** field.
5. Make sure that the correct autofocus mode is selected from the **Focus Mode** drop-down list.
6. Set the dose in the **Dose** field.
7. Set the focus offset in the **Defoc** field.
8. Select the correction options that you want to use in the *Alignment Correction Options* frame:

- If you want to use the substrate rotation angle, select **Use** next to **Rotation**.

This option is recommended.

The substrate angle represents the rotation of the substrate on the chuck. The system measured the substrate angle during the find center procedure. The alignment is rotated by the substrate angle to compensate the substrate rotation.

The substrate angle is particularly relevant for small substrates, which are usually difficult to load perfectly straight.

- If you want to scale the aligned design, select **Use** next to **Scaling X/Y**.

This option requires at least 3 measured alignment marks.

The system compares the measured distance between the alignment marks. A scaling factor is calculated from the deviation. Based on the scaling factor, the aligned design is resized to the previous layer.

- If you want to compensate distortions, select **Use** next to **Shearing**.

The system tries to compensate small distortions, such as rectangles that resemble a parallelogram.

9. If you selected bitmaps to expose during the job setup, select **Expose the Bitmaps** to activate the exposure of the bitmaps.
 - ✓ You see a table that shows the positions of the bitmaps below the checkbox.
 - Click **Edit** to edit the values in the table.
 - Click **Original** to reset the values in the table.
10. If you want to automatically unload the substrate when the exposure is completed, select **Auto-Unload the Substrate**.
 - If you want to remove the substrate from the chuck for further processing after the exposure, select this option. Then, the unloading procedure starts automatically after the exposure is completed.
 - If you want to keep the substrate on the chuck after the exposure, deselect this option. Then, the system asks you if you want to unload when the exposure is completed.
11. If you want to set a waiting time before the exposure starts, select **Delay Exposure** and set the time.
12. If you want to add a comment, enter the comment in the **Comment** field.

Now, the setup of the exposure parameters is completed. Continue with the steps below.

8.2.10 EXECUTE EXPOSURES

Perform the following steps to execute the exposure:

1. Click **Start Exposure** in the *Proceed* frame.
 - ✓ The system performs an online conversion of the design.
 - ✓ The exposure starts.
 - ✓ You see information about the exposure progress in the *Progress Info* frame.
 - ✓ If **Auto-Unload Substrate** is deselected, the *Exposure Finished* dialog box opens.
2. If the *Exposure Finished* dialog box opens, choose if you want to unload the substrate:
 - **Yes:** Start the unloading procedure.
Continue with unloading the substrate. For more information, see "7.2 Unload substrates", page 87.
 - **No:** Keep the substrate loaded, for example, to expose another layer on the same substrate.
- ✓ The *Setup Job* frame opens.
- ✓ The exposure of the layer is completed.
3. If you want to add another layer, click **Add Layer** and repeat the steps that you performed for the previous layer.
Repeat this step until you exposed all necessary layers.

Now, the procedure is completed. Continue with one of the following options:

- If you want to save the job with the current parameters and settings, click **Save Job** in the *Job* frame.
- If you want to repeat the job, click **Repeat Job** in the *Job* frame.
- If you want to start another operation, follow the instructions for the operation that you want to perform.

8.3 Execute field-aligned exposures

The following procedure explains how to execute field-aligned exposures.

For field-aligned exposures, an additional alignment mark is exposed in each exposed field. Then, the design of each subsequent layer is aligned with the alignment mark in the same field.

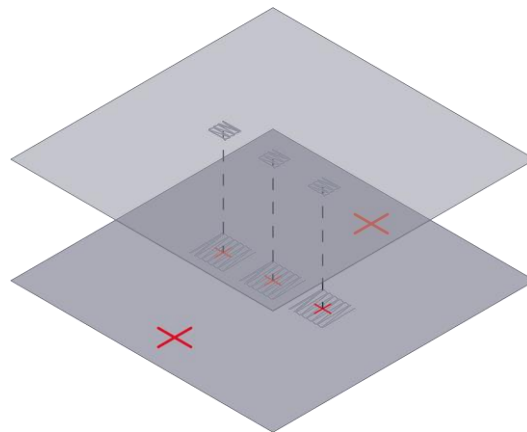

Fig. 82: Field alignment – Designs aligned to field alignment marks

In general, field-aligned exposures are similar to multi-layer exposures, which use only global alignment. But to execute field-aligned exposures, you need to prepare the required alignment marks and perform some additional steps.

First, at least 2 global alignment marks are needed, which are outside the area where the designs are to be exposed. The global alignment marks should be placed as far as possible from each other.

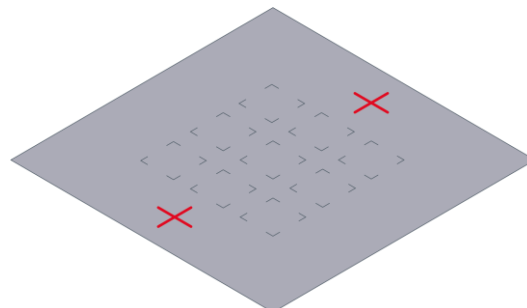

Fig. 83: Field alignment – Global alignment marks

Additionally, a grid with field alignment marks is needed inside the area where the designs are to be exposed. The field alignment marks can be exposed together with the global alignment marks. You need one field alignment mark per cell (*field*) in the grid. Later, each design that you expose is aligned with the field alignment mark of the field in which it is exposed.

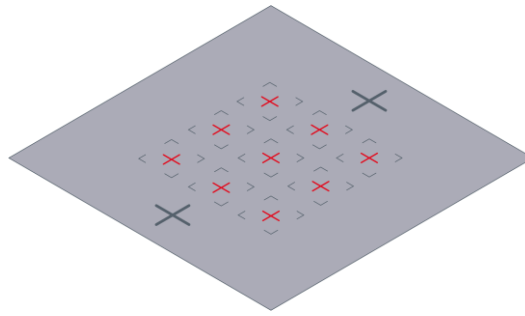

Fig. 84: Field alignment – Field alignment marks

The fields are identified by an index, which represents the position of the field on the x-axis and the y-axis. To identify the position of the field alignment mark in the field, each field in the grid has its own coordinate system.

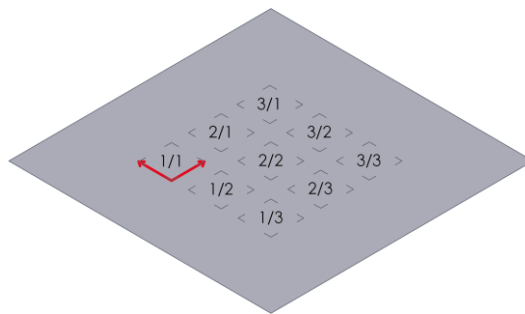

Fig. 85: Field alignment – Indexes and field coordinate systems

8.3.1 SET UP JOBS

Note that the following instruction may contain steps related to features, options, or objects that are not available for your system. Skip the steps that are not relevant for you.

Perform the following steps to set up the first layer:

1. Create or load a job.

- For more information about creating a job, see "6.3 Create jobs", page 77.

If you create a new job, you must set all required parameters. The steps below explain how to set the required parameters.

- For more information about loading a job, see "6.4 Load jobs", page 78.

If you load an existing job, you do not need to set all parameters again, but you must carefully check all parameters for correctness and completeness. The steps below support you with the evaluation of the parameters.

2. Select **Standard** from the **Exposure Mode** drop-down list in the *Job* frame of the *Setup Job* frame.

✓ You see the *Layer* frame in the *Setup Job* frame.

✓ You see **FirstExposure** in the field below **Layer** in the *Layers* table.

The **FirstExposure** row is for the definition and exposure of the alignment marks that you use for the exposure of the subsequent layers.

3. Double-click the field below **Substrate Template** of the *Substrate* frame.
 - ✓ The *Load Substrate* frame opens.
4. Select the substrate template that you want to use from the *Substrate Templates* table.

If you do not want to use a substrate template, set the parameters of the substrate that you want to use in the *Characteristics* frame and, if required, in the *Advanced Parameters* frame.
5. Click **Load** in the *Load* frame to confirm.
 - ✓ The *Setup Job* frame opens.
 - ✓ You see the parameters of the substrate in the *Substrate* frame.
6. Click the field below **Laser** in the **FirstExposure** row of the *Layer* frame and select the laser that you want to use from the drop-down list.
7. Click the field below **Laser Power** in the **FirstExposure** row of the *Layer* frame and select the light intensity that you want to use from the drop-down list.
8. Click the field below **Focus Mode** in the **FirstExposure** row of the *Layer* frame and select the focus mode that you want to use from the drop-down list.
9. Double-click the field below **Design** in the **FirstExposure** row of the *Layer* frame.
 - ✓ The *Load Design* frame opens.
10. Select the design that you want to expose on the first layer from the *Designs* table.
11. Click **Load** in the *Load* frame to confirm.
 - ✓ The *Setup Job* frame opens.
 - ✓ You see the name of the design in the field below **Design** in the **FirstExposure** row of the *Layer* frame.
12. Double-click the field below **Exposure Bitmaps** in the **FirstExposure** row of the *Layer* frame to set up the alignment marks that you want to expose.
 - ✓ The *Load Exposure Bitmaps* frame opens.
13. Select the bitmap template that you want to use from the *Bitmap Templates* table.
14. Click **Load** in the *Load* frame to confirm.
 - ✓ The *Setup Job* frame opens.
 - ✓ You see the name of the bitmap template in the field below **Exposure Bitmaps** in the **FirstExposure** row of the *Layer* frame.
15. If you selected a grayscale design or if you want to set the resist thickness, double-click the field below **Resist** in the in the **FirstExposure** row of the *Layer* frame.

If you expose a grayscale design, this step is mandatory. Else, this step is optional.

 - ✓ The *Load Resist* frame opens.
16. Select the resist template that you want to use from the *Resists* table.

17. Click **Load** in the *Load* frame to confirm.
 - ✓ The *Setup Job* frame opens.
 - ✓ You see the name of the resist in the field below **Resist** in the **FirstExposure** row of the *Layer* frame.
18. If you want to activate the high aspect ratio mode, click the field below **HAR** in the **FirstExposure** row of the *Layer* frame and select the high aspect ratio mode that you want to use from the drop-down list.
19. If you want to save the job with the current parameters, click **Save Job** in the *Job* frame.

Now, the setup of the first layer is completed. Continue with the steps below.

8.3.2 LOAD SUBSTRATES

Perform the following steps to load a substrate:

1. Choose one of the following options:
 - If the substrate that you want to use is not yet loaded, click **Load Substrate** in the *Proceed* frame.
 - ✓ The stage moves into the loading position.
Continue with loading a substrate onto the chuck. For more information, see "7.1 Load substrates", page 80.
 - If the substrate that you want to use is already loaded, click **First Exposure** in the *Proceed* frame.
 - ✓ The *First Exposure* frame opens.
Continue with setting up the exposure parameters. For more information, see "8.3.3 Set up exposure parameters", page 118.
2. When the substrate is successfully loaded onto the chuck, click **Continue** in the *Proceed* frame.
 - ✓ The system measures the loaded substrate.
Troubleshooting:
If the substrate size was not completely defined, a dialog box opens and asks how to proceed. Select one of the available options to solve the issue.
3. Make sure that the substrate is located under the write head.
 - Troubleshooting:
If the substrate is not located under the write head, click **Cancel** in the *Proceed* frame. Then, restart the loading procedure to solve the issue.
4. Click **Continue** in the *Proceed* frame.
 - ✓ The system starts a find plate center procedure to detect the center of the substrate.

Troubleshooting if the system cannot detect the center of the substrate or if the system does not detect the center of the substrate correctly:

- Manually determine the center and rotation of the substrate.

For more information, see "8.6 Find substrate centers", page 143.

You see information about the progress status on the screen.

✓ When the procedure is successfully completed, the *First Exposure* frame opens.

Now, the loading procedure is completed. Continue with the steps below.

8.3.3 SET UP EXPOSURE PARAMETERS

Note that the following instruction may contain steps related to features, options, or objects that are not available for your system. Skip the steps that are not relevant for you.

Perform the following steps to set up the exposure parameters for the first layer:

1. Make sure that the correct design is set in the **Design Name** field.
2. Make sure that the correct wavelength is set for the laser in the **Laser** field.
3. Make sure that the correct light intensity is set in the **Laser Power** field.
4. Make sure that the correct high aspect ratio mode is set in the **High Aspect Ratio** field.
5. Make sure that the correct autofocus mode is selected from the **Focus Mode** drop-down list.
6. Set the dose in the **Dose** field.
7. Set the focus offset in the **Defoc** field.
8. If you want to rotate the design by the substrate angle, select **Expose with Substrate Angle**.

The substrate angle represents the rotation of the substrate on the chuck. The system measured the substrate angle during the find center procedure. The design is rotated by the substrate angle to compensate the substrate rotation.

The substrate angle is particularly relevant for small substrates, which are usually difficult to load perfectly straight.

9. If you selected a grayscale design, select **Set individual Doses for each Bitlayer**.

This option is only available if you selected a design that is applicable for grayscale exposure.

Set the individual doses for the bit layers in the table below the checkbox.

10. Select **Expose the Bitmaps** and make sure that the alignment marks to be exposed are set correctly.

✓ You see a table that shows the coordinates of the alignment marks below the checkbox.

- Make sure that you set at least 2 global alignment marks.
- Make sure that the global alignment marks are outside the grid where you want to expose the designs later.

- Make sure that the global alignment marks are placed as far as possible from each other.
- Make sure that you set 1 field alignment mark in each cell of the grid where you want to expose the designs later.

You do not necessarily need to expose a design in every grid cell later. In a later step, you can individually activate and deactivate fields for exposure.

You can edit the values in the table.

- Click **Edit** to edit the values in the table.
- Click **Original** to reset the values in the table.

If you expose alignment marks, selecting also **Expose with Global Angle** is recommended.

- ✓ The setup of the alignment marks is completed.
11. If you want to set a waiting time before the exposure starts, select **Delay Exposure** and set the time.
 12. If you want to automatically unload the substrate when the exposure is completed, select **Auto-Unload the Substrate**.
 - If you want to remove the substrate from the chuck for further processing after the exposure, select this option. Then, the unloading procedure starts automatically after the exposure is completed.
 - If you want to keep the substrate on the chuck after the exposure, deselect this option. Then, the system asks you if you want to unload when the exposure is completed.
 13. If you want to add a comment, enter the comment in the **Comment** field.

Now, the setup of the exposure parameters is completed. Continue with the steps below.

8.3.4 EXECUTE EXPOSURES

Perform the following steps to execute the exposure:

1. Click **Start Exposure** in the *Proceed* frame.
 - ✓ The system performs an online conversion of the design.
 - ✓ The exposure starts.
 - ✓ You see information about the exposure progress in the *Progress Info* frame.
 - ✓ If **Auto-Unload Substrate** is deselected, the *Exposure Finished* dialog box opens.
 2. If the *Exposure Finished* dialog box opens, choose if you want to unload the substrate:
 - **Yes:** Start the unloading procedure.
Continue with unloading the substrate. For more information, see "7.2 Unload substrates", page 87.
 - **No:** Skip the unloading procedure and keep the substrate on the chuck.
- ✓ The *Setup Job* frame opens.

Now, the exposure of the first layer with the alignment marks is completed. Continue with the steps below.

8.3.5 SET UP LAYERS

Perform the following steps to set up another layer:

1. Click **Add Layer** below at the bottom of the *Layer* frame to add another layer.
 - ✓ Another row is added to the *Layers* table. The layer represents the subsequent layer in the exposure.
2. Click the field below **Laser** in the relevant row of the *Layer* frame and select the laser that you want to use from the drop-down list.
3. Click the field below **Laser Power** in the relevant row of the *Layer* frame and select the light intensity that you want to use from the drop-down list.
4. Click the field below **Focus Mode** in the relevant row of the *Layer* frame and select the focus mode that you want to use from the drop-down list.
5. Double-click the field below **Design** in the relevant row of the *Layer* frame.
 - ✓ The *Load Design* frame opens.
6. Select the design that you want to expose on the first layer from the *Designs* table.
7. Click **Load** in the *Load* frame to confirm.
 - ✓ The *Setup Job* frame opens.
 - ✓ You see the name of the design in the field below **Design** in the relevant row of the *Layer* frame.
8. If you want to expose additional alignment marks or other bitmaps, double-click the field below **Exposure Bitmaps** in the relevant row of the *Layer* frame to set up the alignment marks or bitmaps that you want to expose.
 - ✓ The *Load Exposure Bitmaps* frame opens.
9. Select the bitmap template that you want to use from the *Bitmap Templates* table.
10. Click **Load** in the *Load* frame to confirm.
 - ✓ The *Setup Job* frame opens.
 - ✓ You see the name of the bitmap template in the field below **Exposure Bitmaps** in the relevant row of the *Layer* frame.
11. Double-click the field below **Alignment Settings** in the relevant row of the *Layers* frame.
 - ✓ The *Load Alignment Settings* frame opens.
12. Select the alignment template that you want to use from the *Alignments* table.

If you want to manually set the positions of the alignment marks later, select the `_Manual` alignment template. After the exposure is completed, the positions of the manually set alignment marks will be save as a new alignment template. The file name of the alignment template will be `<jobname>_AlignPos_L<layer-number>`.

 - ✓ You see the alignment parameters of the selected alignment template in the *Alignment Settings* frame.

13. If you want to change the alignment parameters, click **Edit** next to the table that shows the coordinates of the alignment marks in the *Alignment Settings* frame.
Adjust the alignment parameters to meet the requirements of your application.
14. Click **Load** in the *Load* frame to confirm.
 - ✓ The *Setup Job* frame opens.
 - ✓ You see the name of the alignment template in the field below **Alignment Settings** in the relevant row of the *Layer* frame.
 - ✓ You see the coordinates of the alignment marks in the *Alignment Info* frame.
15. If you want to save the job with the current parameters, click **Save Job** in the *Job* frame.

Now, the setup of the layer is completed. Continue with the steps below.

8.3.6 LOAD SUBSTRATES

Perform the following steps to load a substrate:

1. Choose one of the following options:
 - If the substrate that you want to use is not yet loaded, click **Load Substrate** in the *Proceed* frame.
 - ✓ The stage moves into the loading position.
Continue with loading a substrate onto the chuck. For more information, see "7.1 Load substrates", page 80.
 - If the substrate that you want to use is already loaded, click **Alignment** in the *Proceed* frame.
 - ✓ The *Alignment* frame opens.
Continue with setting up the alignment parameters. see "8.3.7 Set up global alignment parameters", page 122
2. When the substrate is successfully loaded onto the chuck, click **Continue** in the *Proceed* frame.
 - ✓ The system measures the loaded substrate.
Troubleshooting:
If the substrate size was not completely defined, a dialog box opens and asks how to proceed. Select one of the available options to solve the issue.
3. Make sure that the substrate is located under the write head.
Troubleshooting:
If the substrate is not located under the write head, click **Cancel** in the *Proceed* frame. Then, restart the loading procedure to solve the issue.
4. Click **Continue** in the *Proceed* frame.
 - ✓ The system starts a find plate center procedure to detect the center of the substrate.

Troubleshooting if the system cannot detect the center of the substrate or if the system does not detect the center of the substrate correctly:

- Manually determine the center and rotation of the substrate.

For more information, see "8.6 Find substrate centers", page 143.

You see information about the progress status on the screen.

✓ When the procedure is successfully completed, the *Alignment* frame opens.

Now, the loading procedure is completed. Continue with the steps below.

8.3.7 SET UP GLOBAL ALIGNMENT PARAMETERS

Note that the following instruction may contain steps related to features, options, or objects that are not available for your system. Skip the steps that are not relevant for you.

Perform the following steps to set up the global alignment parameters:

1. Make sure that the correct surface is selected in the drop-down list in the table of the *Alignment Settings* frame.

If you want to make changes, click **Edit** next to the table and select the correct surface:

- If the alignment mark is at the top surface of the substrate, select **Top Surface**.
- If the alignment mark is at the bottom surface of the substrate, select **Back Surface**.

Click **Apply** to confirm.

2. Make sure that the table in the *Alignment Settings* frame shows all relevant alignment marks with the correct coordinates.

- If you want to make changes, click **Edit** next to the table and enter the correct coordinates of the relevant alignment marks in the sequence of execution.
- If you want to reset the coordinates of the alignment marks to the presets in the alignment templates, click **Original** next to the table.

Click **Apply** to confirm.

Now, the setup of the global alignment parameters is completed. Continue with the steps below.

8.3.8 EXECUTE ALIGNMENTS

Note that the following instruction may contain steps related to features, options, or objects that are not available for your system. Skip the steps that are not relevant for you.

NOTE

The optical autofocus can react on very small differences in the substrate topography. It is possible that the optical autofocus identifies structures or irregularities on the substrate surface as alignment marks so that the automatic detection of the alignment marks is not successful.

If issues occur during the automatic detection of the alignment marks, you can align manually or select the pneumatic autofocus for the layer in the job setup.

Perform the following steps to execute the global alignment:

1. Select the alignment mode that you want to use from the **Alignment Mode** drop-down list in the *Cross Measurement* frame.
 - For cross-shaped alignment marks, select **CrossAlignment**.
The system will search for cross-shaped alignment marks at the given positions.
 - For rectangular alignment marks, select **RectangleAlignment**.
The system will search for rectangular alignment marks at the given positions.
 - Alternatively, you can select **ManualAlignment** if the automatic detection is not successful. Then, you can manually navigate to the alignment marks.

You can change the alignment mode for each alignment cross that you want to measure.
2. Select the camera mode that you want to use in the *Camera Control* frame:
 - For small alignment marks, click **High Res**.
The High-Resolution Camera mode shows more detail than the Low-Resolution Camera mode, but it covers a smaller area.
This option is not available for backside alignment.
 - For larger alignment marks, click **Low Res**.
The Low-Resolution Camera mode shows less detail than the High-Resolution Camera mode, but it covers a larger area.
This option is not available for backside alignment.
 - For alignment marks at the bottom surface, click **Backside**.
This option is available only for backside alignment.
 - For navigating and finding the alignment marks on the substrate, click **Overview**.
The Overview Camera mode shows much less detail than the High-Resolution Camera mode and the Low-Resolution Camera mode, but it covers a much larger area. So, the Overview Camera mode is less suitable for alignment.

Note that the alignment mark must be completely visible in the field of view of the camera.

3. If you want to take the substrate angle into account when moving to the first cross, activate the **Use Angle** checkbox.
4. Click **Move To First Cross**.
 - ✓ The camera automatically moves to the first alignment mark.
5. If the camera does not move to the first alignment mark automatically, perform the following steps:
 1. Use the visualization of the substrate in the *Substrate* frame of the *Alignment* frame to move the camera to the first alignment mark.
To move the camera, double-click the desired position in the *Substrate* frame.
 - ✓ The camera moves to the desired position.
 2. Move the camera until you see the alignment mark in the camera live view.
 3. Center the + icon of the camera live view above the alignment mark.
 - ✓ The camera live view is centered above the first alignment mark.
6. Adjust the values in the **Focus** field and in the **Brightness** field of the *Camera Control* frame until the camera live view shows the best-possible contrast.
 - ✓ The setup of the alignment marks and the camera live view are completed.
7. Click **Measure** in the *Cross Measurement* frame.
 - ✓ The system starts the measurement procedure.

If **CrossAlignment** or **RectangleAlignment** is selected, the system automatically moves to the position of the first alignment mark and you see the alignment mark in the camera live view. Skip the next step.

If **ManualAlignment** is selected, the stage must be manually moved to position of the first alignment mark to see the alignment mark in the camera live view.
8. If **ManualAlignment** is selected, manually measure the first alignment mark:
 8. Use the arrow buttons in the *Stage Control* frame to move to the stage to the position of the first alignment mark.
Note that the alignment mark must be completely visible and must completely fill the field of view of the camera.
 9. If the alignment mark is not completely visible or does not completely fill the field of view of the camera, click **ResizeDetectionArea** and resize the detection area rectangle in the camera live view.
To reset the size of the detection area, click **MaximizeDetectionArea**.
 10. In the camera list view, move the + icon to the center of the alignment mark.
 11. In the center of the alignment mark, set a square frame by pressing the S key or set a circular frame by pressing the C key.
 - ✓ You see the frame in the center of the alignment mark.

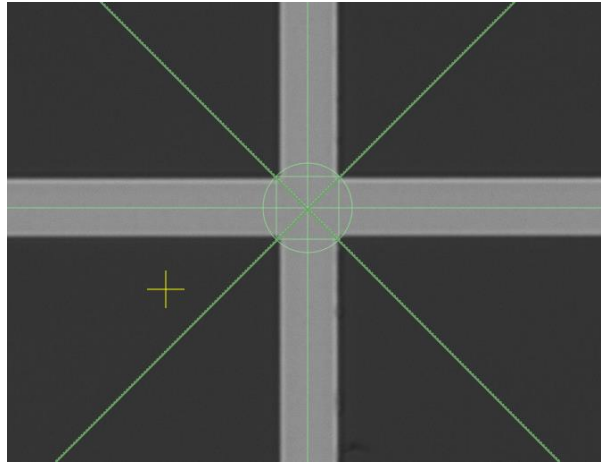

Fig. 86: Camera – Manual Alignment – Alignment center frame

If the frame is not correctly positioned, you can remove the frame by pressing the S key or the C key again.

12. Click to confirm.

✓ The **+** icon becomes orange.

13. Adjust the size of the frame by scrolling with mouse wheel.

To adjust the size in larger steps, hold the Ctrl key while scrolling with the mouse wheel.

14. Click **Center Cross** to center the camera live view to the frame.

✓ You see the center of the alignment mark in the camera live view.

9. If the alignment mark is the only alignment mark that you measure, adjust the value in the **Set Angle** field so that the crosshair in the camera live view exactly matches the alignment mark rotation.

This setting is helpful for small substrates that are too small for more than a single alignment mark.

For fine adjustment, you have the following options in the camera live view:

- To move the crosshair in steps of 1 pixel, use the arrow keys.
- To rotate the crosshair in steps of 1 mRad, hold the Ctrl key and use the ↑ and ↓ arrow keys.
- To rotate the crosshair in steps of 0.1 mRad, hold the Alt key and use the ↑ and ↓ arrow keys.

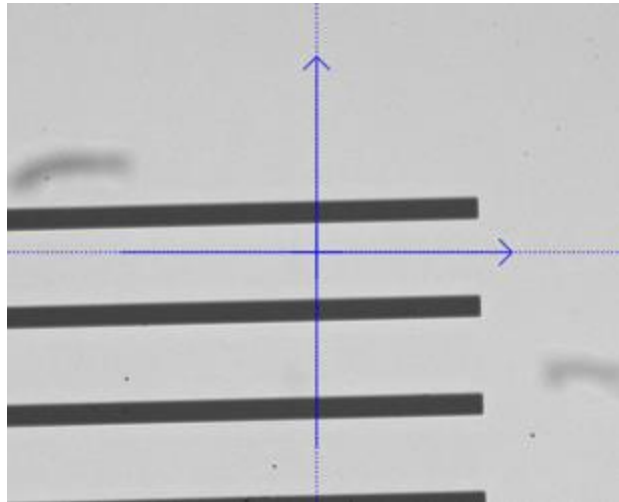

Fig. 87: Camera – Angle – Before adjustment

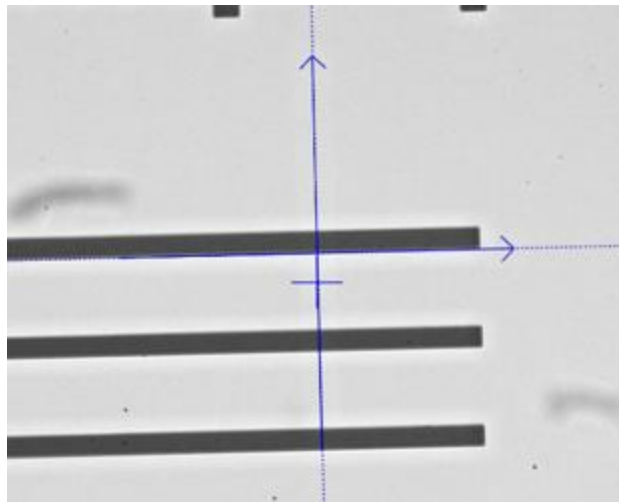



Fig. 88: Camera – Angle – After adjustment

Click  in the top right corner of the camera live view to confirm.

10. If the alignment mark is correctly displayed in the camera live view, click **Accept Position** in the *Cross Measurement* frame.

Troubleshooting if the alignment result is not correct or not satisfying:

- Click **Re-Measure** in the *Cross Measurement* frame to restart the measurement.
- If the alignment mark is not completely visible or does not completely fill the field of view of the camera, click **ResizeDetectionArea** and resize the detection area rectangle in the camera live view.

To resize the detection area rectangle, drag the corners of the rectangle.

To reset the size of the detection area, click **MaximizeDetectionArea**.

- If the system cannot detect the alignment, adjust the values in the **Focus** field and in the **Brightness** field of the *Camera Control* frame.
- If you use a very thick resist, select **Tools » Large Camera Defoc** from the menu bar to activate the extended camera offset.

To set the extended camera offset, adjust the value in the **Range** field of the *Camera Control* frame.

- ✓ The measurement of the alignment mark is completed.
11. Repeat the steps for every alignment mark.
- ✓ The measurement of all alignment marks is completed.
 - ✓ When the procedure is successfully completed, the *Alignment Exposure* frame opens.

Now, the global alignment is completed. Continue with the steps below.

8.3.9 SET UP EXPOSURE PARAMETERS

Note that the following instruction may contain steps related to features, options, or objects that are not available for your system. Skip the steps that are not relevant for you.

Perform the following steps to set up the exposure parameters:

1. Make sure that the correct design is set in the **Design Name** field.
2. Make sure that the correct wavelength is set for the laser in the **Laser** field.
3. Make sure that the correct light intensity is set in the **Laser Power** field.
4. Make sure that the correct high aspect ratio mode is set in the **High Aspect Ratio** field.
5. Make sure that the correct autofocus mode is selected from the **Focus Mode** drop-down list.
6. Set the dose in the **Dose** field.
7. Set the focus offset in the **Defoc** field.
8. Select the correction options that you want to use in the *Alignment Correction Options* frame:

- If you want to use the substrate rotation angle, select **Use** next to **Rotation**.

This option is recommended.

The substrate angle represents the rotation of the substrate on the chuck. The system measured the substrate angle during the find center procedure. The alignment is rotated by the substrate angle to compensate the substrate rotation.

The substrate angle is particularly relevant for small substrates, which are usually difficult to load perfectly straight.

- If you want to scale the aligned design, select **Use** next to **Scaling X/Y**.

This option requires at least 3 measured alignment marks.

The system compares the measured distance between the alignment marks. A scaling factor is calculated from the deviation. Based on the scaling factor, the aligned design is resized to the previous layer.

- If you want to compensate distortions, select **Use** next to **Shearing**.

The system tries to compensate small distortions, such as rectangles that resemble a parallelogram.

9. If you selected bitmaps to expose during the job setup, select **Expose the Bitmaps** to activate the exposure of the bitmaps.
 - ✓ You see a table that shows the positions of the bitmaps below the checkbox.
 - Click **Edit** to edit the values in the table.
 - Click **Original** to reset the values in the table.
10. If you want to automatically unload the substrate when the exposure is completed, select **Auto-Unload the Substrate**.
 - If you want to remove the substrate from the chuck for further processing after the exposure, select this option. Then, the unloading procedure starts automatically after the exposure is completed.
 - If you want to keep the substrate on the chuck after the exposure, deselect this option. Then, the system asks you if you want to unload when the exposure is completed.
11. If you want to set a waiting time before the exposure starts, select **Delay Exposure** and set the time.
12. If you want to add a comment, enter the comment in the **Comment** field.

Now, the setup of the exposure parameters is completed. Continue with the steps below.

8.3.10 SET UP FIELD ALIGNMENT PARAMETERS

Perform the following steps to set up the field alignment parameters:

1. Select **Expose the Design several times in a Map using Field Alignment** in the *Field Alignment* frame.
 - ✓ You see additional frames with parameters for the setup of the field alignment in the *Field Alignment* frame.
2. If you want to load an existing field alignment setup, click **Load** in the *Load and Save* frame and select the setup that you want to load.
 - ✓ You see parameters of the loaded field alignment setup in the *Map Parameters* frame.
3. Set the number of fields in the **Number of Fields** fields of the *Map Parameters* frame.
 - The number of fields on the x-axis represents the number of rows in the grid.
 - The number of fields on the y-axis represents the number of columns in the grid.
4. Set the index of the starting field in the **Measure Cross Number** fields of the *Map Parameters* frame.

The starting field is the field at which you want to start the measurement.
5. Set the distance between the fields on that were exposed on the previous layer in the **Step Size** fields of the *Map Parameters* frame.

6. Set the position of the alignment marks within the fields in the **Position of Cross** field of the *Map Parameters* frame.

Note that the position that you set are the x/y-coordinates in the grid cell.

Now, the setup of the field alignment parameters is completed. Continue with the steps below.

8.3.11 EXECUTE ALIGNMENTS

Perform the following steps to execute the field alignment:

1. Use the arrow buttons in the *Stage Control* frame to move to the stage to the position of the starting field.

The starting field is the field that you have set in the **Measure Cross Number** field.

- ✓ You see the alignment cross of the starting field in the camera live view.
2. Click **Measure** in the *Cross Measurement* frame.
- ✓ The system starts the measurement procedure.
 - ✓ The system measures all field alignment marks in the grid.
3. If the alignment marks are correctly displayed in the camera live view, click **Accept Position** in the *Cross Measurement* frame.

- ✓ The measurement of the field alignment marks is completed.

Now, the field alignment is completed. Continue with the steps below.

8.3.12 EXECUTE EXPOSURES

Perform the following steps to execute the exposure:

1. Click **Start Exposure** in the *Proceed* frame.
- ✓ The system performs an online conversion of the design.
 - ✓ The exposure starts.
 - ✓ You see information about the exposure progress in the *Progress Info* frame.
 - ✓ If **Auto-Unload Substrate** is deselected, the *Exposure Finished* dialog box opens.
2. If the *Exposure Finished* dialog box opens, choose if you want to unload the substrate:
 - **Yes:** Start the unloading procedure.
Continue with unloading the substrate. For more information, see "7.2 Unload substrates", page 87.
 - **No:** Keep the substrate loaded, for example, to expose another layer on the same substrate.
- ✓ The *Setup Job* frame opens.
 - ✓ The exposure of the layer is completed.
3. If you want to add another layer, click **Add Layer** and repeat the steps that you performed for the previous layer.

Repeat this step until you exposed all necessary layers.

Now, the procedure is completed. Continue with one of the following options:

- If you want to save the job with the current parameters and settings, click **Save Job** in the *Job* frame.
- If you want to repeat the job, click **Repeat Job** in the *Job* frame.
- If you want to start another operation, follow the instructions for the operation that you want to perform.

8.4 Execute exposure series

The following procedure explains how to execute exposure series.

The exposure series is a set of fields (*dies*) with the same design that are exposed one after the other with continuously incrementing parameters. You can create a dose series, a focus offset series, or a dose / focus offset matrix. After the exposure, you can compare the results to check for the settings that produce the best results for your individual application.

8.4.1 SET UP JOBS

Note that the following instruction may contain steps related to features, options, or objects that are not available for your system. Skip the steps that are not relevant for you.

Perform the following steps to set up an exposure series job:

1. Create or load a job.
 - For more information about creating a job, see "6.3 Create jobs", page 77.
If you create a new job, you must set all required parameters. The steps below explain how to set the required parameters.
 - For more information about loading a job, see "6.4 Load jobs", page 78.
If you load an existing job, you do not need to set all parameters again, but you must carefully check all parameters for correctness and completeness. The steps below support you with the evaluation of the parameters.
2. Select **Series** from the **Exposure Mode** drop-down list in the *Job* frame of the *Setup Job* frame.
 - ✓ You see the *Series* frame in the *Setup Job* frame.
3. Double-click the field below **Substrate Template** in the *Substrate* frame.
 - ✓ The *Load Substrate* frame opens.
4. Select the substrate template that you want to use from the *Substrate Templates* table.
If you do not want to use a substrate template, set the parameters of the substrate that you want to use in the *Characteristics* frame.
5. Click **Load** in the *Load* frame to confirm.
 - ✓ The *Setup Job* frame opens.
 - ✓ You see the parameters of the substrate in the *Substrate* frame.

6. Click the field below **Series Template** in the *Series* frame.
 - ✓ The *Load Series* frame opens.
 7. Select the series template that you want to use from the *Series Templates* table.

Note that you can adjust the parameters of the series in a later step.
 8. Click **Load** in the *Load* frame to confirm.
 - ✓ The *Setup Job* frame opens.
 - ✓ You see the parameters of the series in the *Series* frame.
 9. Click the field below **Laser** in the *Layer* frame and select the laser that you want to use from the drop-down list.
 10. Click the field below **Laser Power** in the *Layer* frame and select the default light intensity that you want to use from the drop-down list.

You can adjust the light intensity for the series in a later step.
 11. Click the field below **Focus Mode** in the *Layer* frame and select the focus mode that you want to use from the drop-down list.
 12. Double-click the field below **Design** in the *Series* frame.
 - ✓ The *Load Design* frame opens.
 13. Select the design that you want to use from the *Designs* table.
 14. Click **Load** in the *Load* frame to confirm.
 - ✓ The *Setup Job* frame opens.
 - ✓ You see the name of the design in the field below **Design** in the *Series* frame.
 15. If you selected a grayscale design or if you want to set the resist thickness, double-click the field below **Resist** in the *Series* frame.

If you expose a grayscale design, selecting the resist is required. Else, selecting the resist is optional.

 - ✓ The *Load Resist* frame opens.
 16. Select the resist that you want to use from the *Resists* table.
 17. Click **Load** in the *Load* frame to confirm.
 - ✓ The *Setup Job* frame opens.
 - ✓ You see the name of the resist in the field below **Resist** in the *Layer* frame.
 - ✓ The setup of the job is completed.
 18. If you want to activate the high aspect ratio mode, click the field below **HAR** in the *Layer* frame and select the high aspect ratio mode that you want to use from the drop-down list.
 19. If you want to save the job, click **Save Job** in the *Job* frame.
- Now, the setup of the job. Continue with the steps below.

8.4.2 LOAD SUBSTRATES

Note that the following instruction may contain steps related to features, options, or objects that are not available for your system. Skip the steps that are not relevant for you.

Perform the following steps to load a substrate:

1. Choose one of the following options:

- If the substrate that you want to use is not yet loaded, click **Load Substrate** in the *Proceed* frame.

✓ The stage moves into the loading position.

Continue with loading a substrate onto the chuck. For more information, see "7.1 Load substrates", page 80.

- If the substrate that you want to use is already loaded, click **Series** in the *Proceed* frame.

✓ The *Series* frame opens.

Continue with setting up the exposure parameters. For more information, see "8.4.3 Set up exposure parameters", page 132.

2. When the substrate is successfully loaded onto the chuck, click **Continue** in the *Proceed* frame.

✓ The system measures the loaded substrate.

Troubleshooting:

If the substrate size was not completely defined, a dialog box opens and asks how to proceed. Select one of the available options to solve the issue.

3. Make sure that the substrate is located under the write head.

Troubleshooting:

If the substrate is not located under the write head, click **Cancel** in the *Proceed* frame. Then, restart the loading procedure to solve the issue.

4. Click **Continue** in the *Proceed* frame.

✓ The system starts a find plate center procedure to detect the center of the substrate.

Troubleshooting if the system cannot detect the center of the substrate or if the system does not detect the center of the substrate correctly:

- Manually determine the center and rotation of the substrate.

For more information, see "8.6 Find substrate centers", page 143.

You see information about the progress status on the screen.

✓ When the procedure is successfully completed, the *Series* frame opens.

Now, the loading procedure is completed. Continue with the steps below.

8.4.3 SET UP EXPOSURE PARAMETERS

Perform the following steps to set up the series parameters:

1. Make sure that the correct design is set in the **Design Name** field.

2. Make sure that the correct wavelength is set for the laser in the **Laser** field.
3. Make sure that the correct autofocus mode is selected from the **Focus Mode** drop-down list.
4. Make sure that the correct exposure series mode is selected in the **Series Mode** drop-down list:
 - **Dose:** Select this option to execute a dose series.
The dose increments per field while the focus offset is fixed.
 - **Defoc:** Select this option to execute a focus offset series.
The focus offset increments per field while the dose is fixed.
 - **Dose and Defoc:** Select this option to execute a dose / focus offset matrix.
The dose increments per field on the y-axis and the focus offset increments per field on the x-axis.
5. If you want to execute a dose series or a dose / focus offset matrix, set the following values in the *Dose Series* table:
 1. Set the number of fields that you want to expose per row in the **Number of Fields** field.
 2. Set the starting dose in the **Start Value** field.
 3. Set the increment per field in the **Step Size** field.
Example: If you expose 3 fields with a starting dose of 20 and increment by 10, the first field is exposed with a dose of 20, the second field is exposed with a dose of 30, and the third field is exposed with a dose of 40.
 - ✓ The calculated end value of the series is shown in the **End Value** field.
 4. If you want to adjust the focus position and the focal point of the write head, set the focus offset in the **Fixed Defoc Value** field.
6. If you want to execute a focus offset series or a dose / focus offset matrix, set the following values in the *Defoc Series* table:
 1. Set the number of fields that you want to expose per row in the **Number of Fields** field.
 2. Set the starting focus offset in the **Start Value** field.
 3. Set the increment per field in the **Step Size** field.
Example: If you expose 3 fields with a starting focus offset of 10 and increment by 5, the first field is exposed with a focus offset of 10, the second field is exposed with a focus offset of 15, and the third field is exposed with a focus offset of 20.
 - ✓ The calculated end value of the series is shown in the **End Value** field.
 4. If you want to adjust the dose, set the dose in the **Fixed Dose Value** field.
7. Set the number of rows that you want to expose in the **Number of Rows** field.
8. Set the distance between the fields on the x-axis in the **Step Size in X** field.
- ✓ You see the calculated total width in the **Total Range in X** field.

9. Set the distance between the fields on the y-axis in the **Step Size in Y** field.

You can set the vertical distance only if you expose more than one row.

✓ You see the calculated total height in the **Total Range in Y** field.

10. If you want to expose plain text information about the dose and focus offset below the field, select **Expose Labeling**.



Fig. 89: Exposure Series – Expose Labeling

Note that you need a sufficient distance between the fields on the y-axis if you expose more than one row of fields. If the distance is too small, the **Step Size in Y** field is highlighted in orange.

The information is exposed in an additional exposure step but does not increase the exposure time.

11. If you want to add a comment, enter the comment in the **Comment** field.

12. If you want to automatically unload the substrate when the exposure is completed, select **Auto-Unload the Substrate**.

- If you want to remove the substrate from the chuck for further processing after the exposure, select this option. Then, the unloading procedure starts automatically after the exposure is completed.
- If you want to keep the substrate on the chuck after the exposure, deselect this option. Then, the system asks you if you want to unload when the exposure is completed.

13. If you want to set a waiting time between moving the stage into position and starting the exposure, select **Delay Exposure** and set the time.

14. Check the position of the fields in the *Substrate* frame.

The red rectangles represent the fields on the substrate.

Troubleshooting:

- If the fields overlap, the distance between the fields is too small. Increase the value in the **Step Size in X** or **Step Size in Y** field, respectively.
- If the fields exceed the substrate dimensions, there are too many fields in the series. Decrease the value in the **Number of Fields** field.

Now, the setup of the series parameters is completed. Continue with the steps below.

8.4.4 EXECUTE EXPOSURES

Perform the following steps to execute the exposure:

1. Click **Start Exposure** in the *Proceed* frame.
 - ✓ The system performs an online conversion of the design once. This is used for the first die. The other dies use the same data offline.
 - ✓ The exposure starts.
 - ✓ You see information about the exposure progress in the *Progress Info* frame.
 - ✓ If **Auto-Unload Substrate** is deselected, the *Exposure Finished* dialog box opens.
2. If the *Exposure Finished* dialog box opens, choose if you want to unload the substrate:
 - **Yes:** Start the unloading procedure.
Continue with unloading the substrate. For more information, see "7.2 Unload substrates", page 87.
 - **No:** Keep the substrate loaded, for example, to expose another layer on the same substrate.
- ✓ The *Setup Job* frame opens.

Now, the procedure is completed. Continue with one of the following options:

- If you want to save the job with the current parameters and settings, click **Save Job** in the *Job* frame.
- If you want to repeat the job, click **Repeat Job** in the *Job* frame.
- If you want to start another operation, follow the instructions for the operation that you want to perform.

8.5 Execute ad hoc shape exposures

The following procedure explains how to execute ad hoc shape exposures.

8.5.1 SET UP JOBS

Perform the following steps to set up an ad hoc shape exposure job:

1. Create or load a job.
 - For more information about creating a job, see "6.3 Create jobs", page 77.
If you create a new job, you must set all required parameters. The steps below explain how to set the required parameters.
 - For more information about loading a job, see "6.4 Load jobs", page 78.
If you load an existing job, you do not need to set all parameters again, but you must carefully check all parameters for correctness and completeness. The steps below support you with the evaluation of the parameters.

2. Select **Draw Mode** from the **Exposure Mode** drop-down list in the *Job* frame of the *Setup Job* frame.
 - ✓ You see the *Draw Mode* frame in the *Setup Job* frame.
 3. Double-click the field below **Substrate Template** in the *Substrate* frame.
 - ✓ The *Load Substrate* frame opens.
 4. Select the substrate template that you want to use from the *Substrate Templates* table.

If you do not want to use a substrate template, set the parameters of the substrate that you want to use in the *Characteristics* frame.
 5. Click **Load** in the *Load* frame to confirm.
 - ✓ The *Setup Job* frame opens.
 - ✓ You see the parameters of the substrate in the *Substrate* frame.
 6. Click the field below **Laser** in the *Layer* frame and select the laser that you want to use from the drop-down list.
 7. Click the field below **Laser Power** in the *Layer* frame and select the light intensity that you want to use from the drop-down list.
 8. Click the field below **Focus Mode** in the *Layer* frame and select the focus mode that you want to use from the drop-down list.
 9. If you want to expose alignment marks or other bitmaps, double-click the field below **Exposure Bitmaps** in the *Layer* frame.
 - ✓ The *Load Exposure Bitmaps* frame opens.
 10. Select the bitmap template that you want to use from the *Bitmap Templates* table.
 11. Click **Load** in the *Load* frame to confirm.
 - ✓ The *Setup Job* frame opens.
 - ✓ You see the name of the bitmap template in the field below **Exposure Bitmaps** in the *Layer* frame.
 12. If you want to set the resist thickness, double-click the field below **Resist** in the *Layer* frame.
 - ✓ The *Load Resist* frame opens.
 13. Select the resist template that you want to use from the *Resists* table.
 14. Click **Load** in the *Load* frame to confirm.
 - ✓ The *Setup Job* frame opens.
 - ✓ You see the name of the resist template in the field below **Resist** in the *Layer* frame.
 15. If you want to save the job, click **Save Job** in the *Job* frame.
- Now, the setup of the job is completed. Continue with the steps below.

8.5.2 LOAD SUBSTRATES

Note that the following instruction may contain steps related to features, options, or objects that are not available for your system. Skip the steps that are not relevant for you.

Perform the following steps to load a substrate:

1. Choose one of the following options:

- If the substrate that you want to use is not yet loaded, click **Load Substrate** in the *Proceed* frame.

✓ The stage moves into the loading position.

Continue with loading a substrate onto the chuck. see "7.1 Load substrates", page 80

- If the substrate that you want to use is already loaded, click **Draw Mode** in the *Proceed* frame.

✓ The *Draw Mode* frame opens.

Continue with setting up the exposure parameters. For more information, see "8.5.3 Set up exposure parameters", page 138.

2. When the substrate is successfully loaded onto the chuck, click **Continue** in the *Proceed* frame.

✓ The system measures the loaded substrate.

Troubleshooting:

If the substrate size was not completely defined, a dialog box opens and asks how to proceed. Select one of the available options to solve the issue.

3. Make sure that the substrate is located under the write head.

Troubleshooting:

If the substrate is not located under the write head, click **Cancel** in the *Proceed* frame. Then, restart the loading procedure to solve the issue.

4. Click **Continue** in the *Proceed* frame.

✓ The system starts a find plate center procedure to detect the center of the substrate.

Troubleshooting if the system cannot detect the center of the substrate or if the system does not detect the center of the substrate correctly:

- Manually determine the center and rotation of the substrate.

For more information, see "8.6 Find substrate centers", page 143.

You see information about the progress status on the screen.

✓ When the procedure is successfully completed, the *Draw Mode* frame opens.

Now, the loading procedure is completed. Continue with the steps below.

8.5.3 SET UP EXPOSURE PARAMETERS

Perform the following steps to set up the exposure parameters:

1. Make sure that the correct wavelength is set for the laser in the **Laser** field.
2. Make sure that the correct autofocus mode is selected from the **Focus Mode** drop-down list.
3. Set the dose in the **Dose** field.
4. Set the focus offset in the **Defoc** field.
5. If you want to add a comment, enter the comment in the **Comment** field.
6. If you want to automatically unload the substrate when the exposure process is completed, select **Auto-Unload the Substrate**.

Examples:

- If you want to remove the substrate from the chuck for further processing after the exposure, select this option. Then, the unloading procedure starts automatically after the exposure is completed.
- If you want to keep the substrate on the chuck after the exposure, deselect this option. Then, the system asks you if you want to unload when the exposure is completed.

Now, the setup of the exposure parameters is complete. Continue with the steps below.

8.5.4 DRAW SHAPES

You have the following options to draw ad hoc shapes:

- If you want to draw a rectangle, circle, ellipse, or bitmap, continue with drawing images. For more information, see "Draw images", page 138.
- If you want to draw a line or polygon, continue with drawing lines. For more information, see "Draw lines", page 141.
- If you want to load alignment marks directly from a bitmap file, continue with loading alignment marks. For more information, see "Load alignment marks", page 141.

DRAW IMAGES

Perform the following steps to draw a rectangle, circle, ellipse, or bitmap:

1. Select **Draw Image** in the *Procedure* frame.
 2. Click **Draw Image** in the *Proceed* frame.
 3. Use the arrow buttons in the *Stage Control* frame to move to the stage to the area where you want to draw.
- ✓ You see the area where you want to draw in the camera live view.

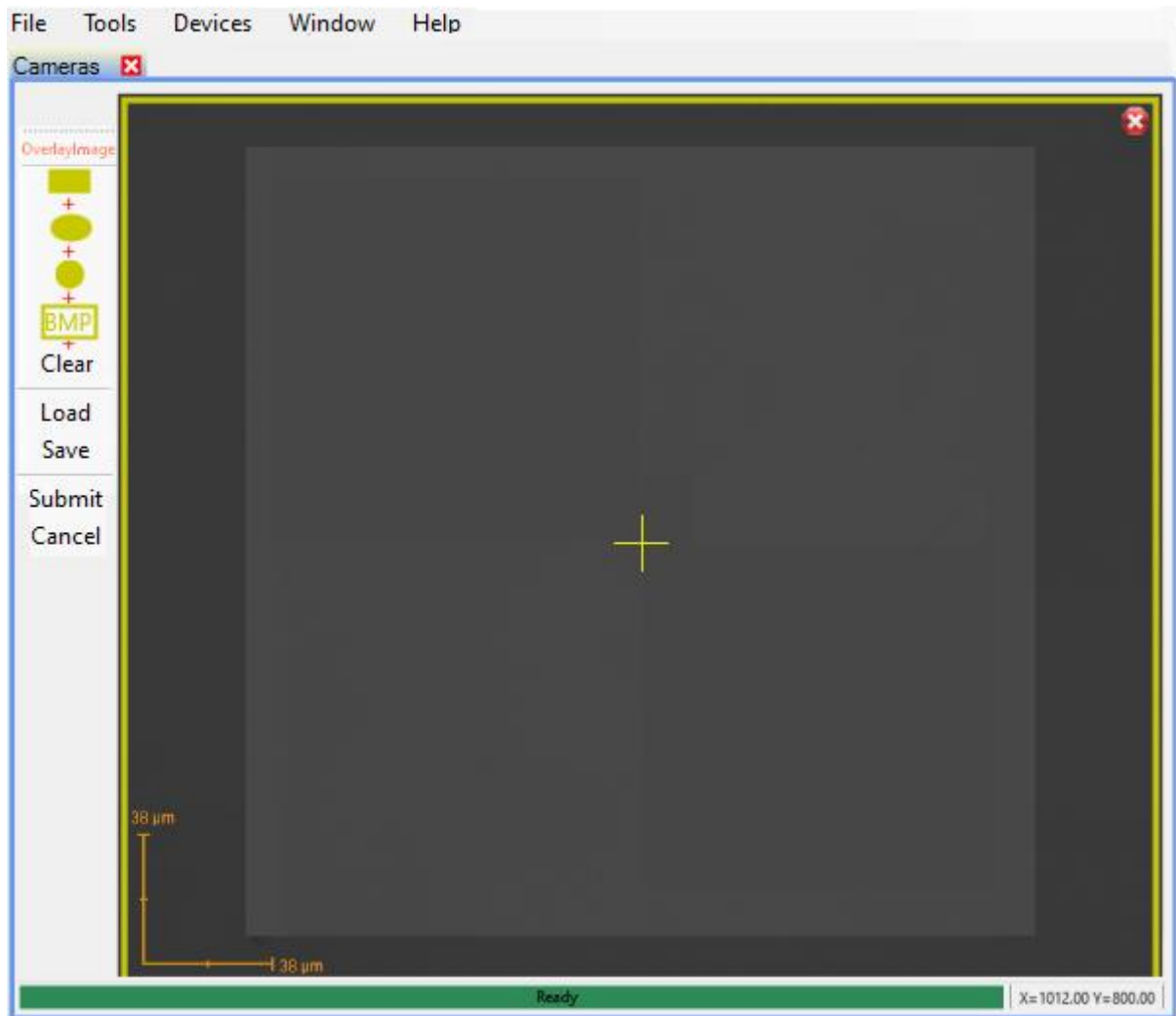





Fig. 90: Camera – Draw Image

4. Select one of the following options from the toolbar next to the camera live view:
 - Click  to draw a rectangle.
 - Click  to draw an ellipse.
 - Click  to draw a circle.
 - Click **BMP** to load a bitmap from the C:\HIMT\Designs\Bitmaps\ directory.
 - Click **Load** to load a saved image.

5. Draw the desired shapes in the camera live view.

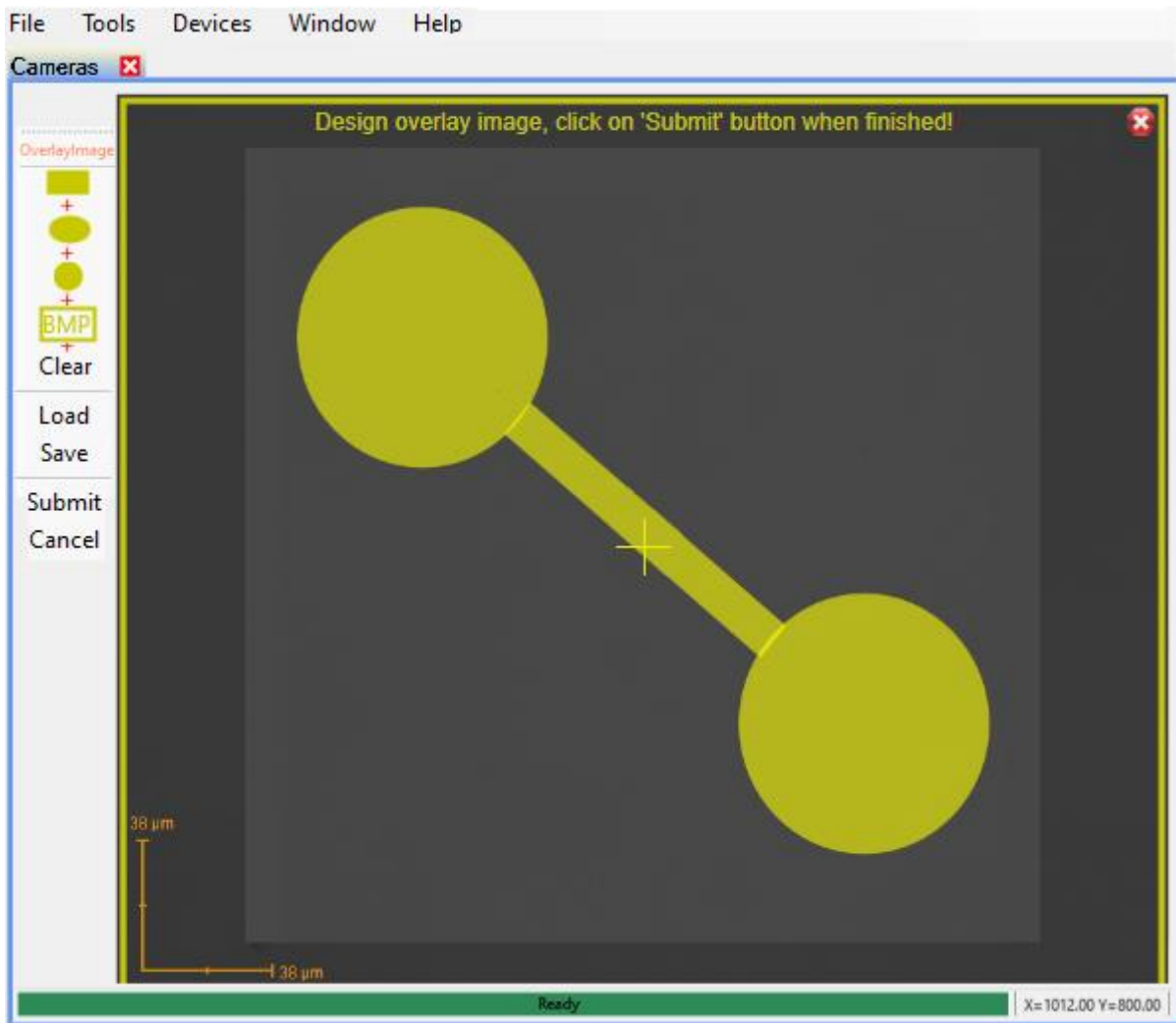

Fig. 91: Camera – Draw Image – Ad hoc shapes

Overlapping shapes are combined into a single image.

- If you want to move a shape, drag the shape and drop it at the desired location.
- If you want to rotate a shape, click ● in the selected shape. Then, rotate while holding the mouse button.
- If you want to save the image, click **Save**.
- If you want to remove a shape, click the shape and click **Clear**.

✓ The image is completed.

6. Click **Submit** to confirm.

Now, the ad hoc shape is completed. Continue with executing the exposure. For more information, see "8.5.5 Execute exposures", page 142.

DRAW LINES

Perform the following steps to draw a line or polygon:

1. Select **Draw Line or Polygon** in the *Procedure* frame.
2. Use the arrow buttons in the *Stage Control* frame to move to the stage to the area where you want to set the first point.
3. Click **Set Point** in the *Proceed* frame.
4. Move the crosshair in the camera live view to the position at which you want to set the first point.

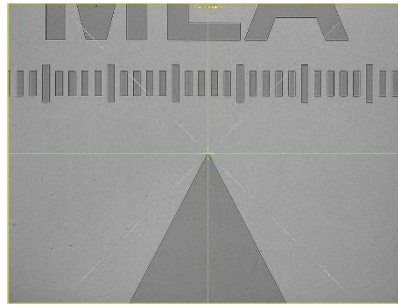

Fig. 92: Camera – Draw Line or Polygon – Set Point

5. Click anywhere to confirm the point at the position of the crosshair.
6. Repeat the steps to draw the second point.
- ✓ You see a line in the camera live view.
7. Click **Accept Line** in the *Proceed* frame.
8. If you want to draw a polygon with more than 2 points, repeat the steps above and click **Accept Polygon** in the *Proceed* frame.

Now, the ad hoc shape is completed. Continue with executing the exposure. For more information, see "8.5.5 Execute exposures", page 142.

LOAD ALIGNMENT MARKS

Note that the following instruction may contain steps related to features, options, or objects that are not available for your system. Skip the steps that are not relevant for you.

Perform the following steps to load alignment marks directly from a bitmap file:

1. Select **Expose Crosses** in the *Procedure* frame.
- ✓ You see additional parameters for the setup of alignment marks in the *Alignment Settings* frame.
2. Click **Edit** in the *Alignment Settings* frame.
3. Make sure that the correct surface is selected in the drop-down list in the table of the *Alignment Settings* frame.
 - If the alignment mark is at the top surface of the substrate, select **Top Surface**.
 - If the alignment mark is at the bottom surface of the substrate, select **Back Surface**.

4. Set all relevant alignment marks with the correct coordinates in the *Alignment Settings* frame.

If you want to reset the coordinates of the alignment marks to the presets in the alignment templates, click **Original** next to the table.

5. If you did not already select a bitmap template file in the *Setup Job* frame, select a bitmap file for each alignment mark from the drop-down lists next to the alignment position table in the *Alignment Settings* frame.

If you want to use the same bitmap file for all alignment marks, select the bitmap file once and select **Use first bitmap for all**.

6. Click **Apply** to confirm.

Now, the ad hoc shape is completed. Continue with executing the exposure. For more information, see "8.5.5 Execute exposures", page 142.

8.5.5 EXECUTE EXPOSURES

Perform the following steps to execute the exposure:

1. Click **Start Exposure** in the *Proceed* frame.
 - ✓ The system performs an online conversion of the design.
 - ✓ The exposure starts.
 - ✓ You see information about the exposure progress in the *Progress Info* frame.
 - ✓ If **Auto-Unload Substrate** is deselected, the *Exposure Finished* dialog box opens.
2. If the *Exposure Finished* dialog box opens, choose if you want to unload the substrate:
 - **Yes:** Start the unloading procedure.
Continue with unloading the substrate. For more information, see "7.2 Unload substrates", page 87.
 - **No:** Keep the substrate loaded, for example, to expose another layer on the same substrate.
- ✓ The *Setup Job* frame opens.

Now, the procedure is completed. Continue with one of the following options:

- If you want to save the job with the current parameters and settings, click **Save Job** in the *Job* frame.
- If you want to repeat the job, click **Repeat Job** in the *Job* frame.
- If you want to start another operation, follow the instructions for the operation that you want to perform.

8.6 Find substrate centers

The following procedure explains how to manually set the center of the substrate before you start the exposure.

Manually setting the center of the substrate is needed if the system cannot detect the center of the substrate or if the system does not detect the center of the substrate correctly during the find center procedure. Especially when loading small substrates with a size of less than 10 mm, the automatic detection of the substrate center is not successful because of technical restrictions.

Perform the following steps to manually set the center of the substrate:

1. If a dialog box opens, which shows that the automatic centering was not successful, click **OK** to confirm.
- ✓ The dialog box closes.
2. In the camera live view, move the **+** icon to the position of the substrate center.

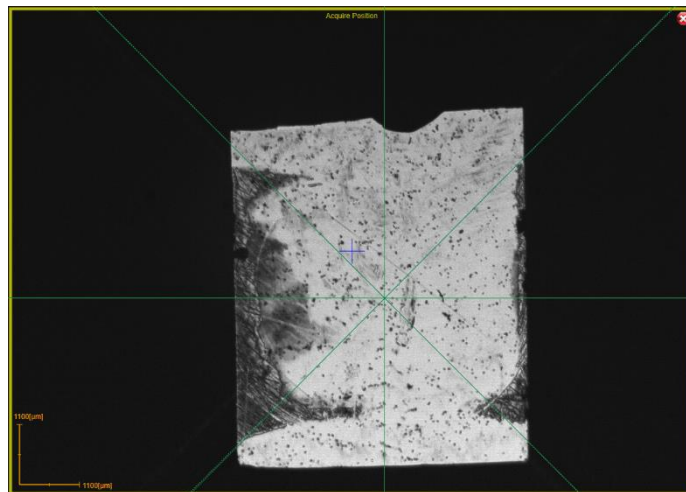

Fig. 93: Camera – Acquire Position

- ✓ You see the **+** icon at the correct position of the substrate center in the camera live view.

Troubleshooting:

If the **+** icon is not at the correct position, click **Set position** in the *Proceed* frame of the *Load Substrate* frame. Then, you can move the **+** icon again.

3. Click **Continue** in the *Proceed* frame of the *Load Substrate* frame to confirm.

- ✓ The system starts the centering procedure based on the position of the substrate center that you set.
- ✓ When the procedure is successfully completed, the next frame opens.

Now, you can continue with the exposure process. For more information, see the instruction for the operation that you want to perform.

8.7 Check logs

During exposure, the system creates a log file that contains details about the process and a summary of the parameters that are set for the job. You can check the log file after the exposure is completed.

Perform the following steps if you want to check the log files:

1. Open the Windows Explorer.
2. Go to C:\HIMT\LogFiles\Exposure Log\.
3. Open the log file that you want to check.

Now, you can check the log file. You find a summary of the parameters that are set for the job at the end of the log file.

9 Set up templates

9.1 Set up substrate templates

Note that you may need extended user access rights to execute the following instruction. For more information about user access rights, contact the system administrator.

Perform the following steps to set up a substrate template:

1. Create a job.

For more information, see "6.3 Create jobs", page 77.

2. Double-click the field below **Substrate Template** in the *Substrate* frame.

✓ The *Load Substrate* frame opens.

3. Create a new template or edit an existing template.

- If you want to create a new template, click **New** in the *Edit* frame.

- If you want to edit an existing template, select the template that you want to edit from the *Substrate Templates* table and click **Edit** in the *Edit* frame.

If you edit an existing template, you do not need to set all parameters again, but you must carefully check all parameters for correctness and completeness. The steps below support you with the evaluation of the parameters.

✓ The fields in the *Characteristics* frame and the *Advanced Parameters* frame can be edited.

4. Enter the name that you want to set for the template in the **Name** field of the *Characteristics* frame.

5. Select the shape of the substrate from the **Shape** drop-down list in the *Characteristics* frame.

You can choose between rectangular substrates and round wafers.

6. If you selected **Rectangular** from the **Shape** drop-down list, set the exact dimension of the substrate on the x-axis in the **Size X** field of the *Characteristics* frame.

7. If you selected **Rectangular** from the **Shape** drop-down list, set the exact dimension of the substrate on the y-axis in the **Size Y** field of the *Characteristics* frame.

✓ You see the calculated substrate size category in the field above the **Size X** field.

8. If you selected **Wafer** from the **Shape** drop-down list, set the exact diameter of the substrate in the **Diameter** field of the *Characteristics* frame.

9. Set the exact height of the substrate in the **Thickness** field of the *Characteristics* frame.

10. Select **Focus at Thickness** if the write head should move over the chuck only to the specified substrate height during the focusing process.

11. If you edit a substrate template for which a dialog box opened during the loading process and requested to adjust the detection offset, set the detection offset in the **Detection Offset** field.

Note that this value is only for troubleshooting. If the system did not request this adjustment, keep the preset value.

The detection offset adjusts the substrate size that is measured by the system to the substrate size that is given by the manufacturer.

The value that you set for the detection offset must be the difference between the measured value and the expected value.

Examples:

- If the size that is given by the manufacturer is 100 mm and the size that is measured by the system is 100.5 mm, the detection offset must be -0.5 .
- If the size that is given by the manufacturer is 100 mm and the size that is measured by the system is 99.5 mm, the detection offset must be 0.5 .

The value that is measured by the system is displayed in the dialog box that opens during the loading process and that requests to adjust the detection offset.

12. Select the autofocus mode from the **Autofocus Mode** drop-down list in the *Advanced Parameters* frame.

Depending on the job type, the user can change the autofocus mode in the job setup.

13. If you want to use the Overview Camera mode for finding the substrate center, select **Check with Overview Camera** in the *Advanced Parameters* frame.

This setting is useful when loading and centering an extremely small substrate that is fixed on another, larger substrate.

When this setting is activated, the system uses the Overview Camera mode for finding the substrate center during the find center procedure. After focusing on the substrate, the system moves the stage to find all edges of substrate to determine the substrate center.

The accuracy of the detection depends on the reflection properties and shape deviations of the substrate.

14. If you want to deactivate the find center procedure that is part of the loading procedure, select **Skip Find Plate Center** in the *Advanced Parameters* frame.

NOTICE

Only for exceptional cases

Deactivating the find center procedure can lead to collision of the write head nozzle and the substrate, which can damage the system. Also, defocused exposures are possible.

Use this setting only in consultation with the Heidelberg Instruments Mikrotechnik Customer Service and with caution.

This setting is available especially for extremely fragile substrates, such as membranes, which can be damaged by the stage movement.

This setting can also be useful when loading an extremely small substrate that is fixed on another, larger substrate and the system does not properly detect the smaller substrate above and focuses on the larger substrate below. In that case, the find center procedure could lead to collision of the write head nozzle and the substrate.

15. If you want to use the piezo freezing during the find plate center procedure, activate the checkbox **FPC: Use Piezo Freezing** in the *Advanced Parameters* frame. The write head returns to control mode, the piezo returns to its previous value and is unfrozen again.
16. If you want to set the write lens position on the x-axis and the y-axis, set the adjusted position for the x-axis and the y-axis in the **Focus Offset X / Y** fields of the *Advanced Parameters* frame.

NOTICE

Only for exceptional cases

Changing the write head position can lead to collision of the write head nozzle and the substrate, which can damage the system. Also, defocused exposures are possible.

Use this setting with caution and make sure that the entered values will not lead to collision before operation.

This setting can be useful if you want to focus on a position that is not the center of the substrate or the center of the chuck.

Focusing on a position that is not the center of the substrate or the center of the chuck can be useful when loading an extremely small substrate that is fixed on another, larger substrate and the autofocus does not properly detect the small substrate above and focuses on the larger substrate below. In that case, focusing on the center of the substrate could lead to collision between the write head nozzle and the substrate. The value that you set for the offset must be 20 mm from the edges of the small substrate.

17. If you want to ignore the autofocus regulation and set the write head height manually, set the write head position in the **Focus Offset Z** field of the *Advanced Parameters* frame.

NOTICE

Only for exceptional cases

Changing the write head height can lead to collision, which can damage the system. Also, defocused exposures are possible.

Use this setting only in consultation with the Heidelberg Instruments Mikrotechnik Customer Service and with caution.

After focusing on the substrate, the write head can be moved up by the z-offset range and stays at the given height until the substrate is unloaded.

This setting can be useful if you load small substrates by using a carrier substrate and focusing on the substrate that is on the carrier substrate is not possible. Instead, you focus on the carrier substrate. Then, you compensate the height of the substrate that is on the carrier substrate by setting the height of the carrier substrate

as the z-offset. This way, the beam focuses on the small substrate and not on the carrier substrate.

18. If you want to reduce the movement speed of the stage, set the velocity that you want to use in the **Max. Velocity** field of the *Advanced Parameters* frame.

This setting can be useful for fragile substrates, which can be damaged by fast stage movement.

19. If you want to deactivate the air flow of the autofocus, select **Stop Autofocus Air** in the *Advanced Parameters* frame.

If you deactivate the air flow of the autofocus, the air flow is active only while focusing the write head on the substrate. Else, the air flow is stopped.

Note that deactivating the air flow of the autofocus will freeze the write head piezo after focusing. The frozen write head piezo prevents the system to execute a find center procedure. So, the find center procedure will be skipped.

Also, if you deactivate the air flow of the autofocus, the extended camera offset will be activated per default in the exposure parameters of the related jobs. You must explicitly change the camera offset in the exposure parameters to return to the normal camera offset.

You can change the camera offset in the *Tools* menu of the Menu bar. For more information, see "4.1.1 Menu bar", page 31.

20. If you want to manually set the piezo both for the camera and the exposure, select **Expose with Camera Focus** in the *Advanced Parameters* frame.

This setting can be helpful if you load small substrates that are too small for the autofocus.

If you activate this option, activate the extended camera focus for the related jobs. When you activate the extended camera focus, the focus values in the *Camera Control* frame cover the complete range.

You can activate the extended camera focus in the *Tools* menu of the Menu bar. For more information, see "4.1.1 Menu bar", page 31.

If both this option and the extended camera focus are activated for the job, the focus values are linked to each other. When the focus values are linked to each other and the camera focus is used for the exposure.

21. Click **Save** in the *Edit* frame to confirm.

- ✓ The fields in the *Characteristics* frame and the *Advanced Parameters* frame are read-only.

Now, the template is saved and you can select the template for setting up a job.

9.2 Set up resist templates

Note that you may need extended user access rights to execute the following instruction. For more information about user access rights, contact the system administrator.

Note that the following instruction may contain steps related to features, options, or objects that are not available for your system. Skip the steps that are not relevant for you.

Perform the following steps to set up a resist template:

1. Create a job.

For more information, see "6.3 Create jobs", page 77.

2. Select **Standard** from the **Exposure Mode** drop-down list in the *Job* frame of the *Setup Job* frame.

In general, the job type that you select is not relevant for creating the template. The job type only needs to support the selection of a resist template.

- ✓ You see the *Layer* frame in the *Setup Job* frame.

3. Double-click the field below **Resist** in the *Layer* frame.

- ✓ The *Load Resist* frame opens.

4. Create a new template or edit an existing template.

- If you want to create a new template, click **New** in the *Edit* frame.

- If you want to edit an existing template, select the template that you want to edit from the *Resist Templates* table and click **Edit** in the *Edit* frame.

If you edit an existing template, you do not need to set all parameters again, but you must carefully check all parameters for correctness and completeness. The steps below support you with the evaluation of the parameters.

- ✓ The fields in the *Characteristics* frame and the frames below the *Characteristics* frame can be edited.

5. Enter the name that you want to set for the template in the **Name** field of the *Characteristics* frame.

6. Enter the name of the resist that you want to use in the **Resist** field of the *Characteristics* frame.

7. Enter the thickness of the resist in the **Thickness** field of the *Characteristics* frame.

8. Select the laser that is suitable for the resist from the **Wavelength** drop-down list in the *Characteristics* frame.

If more than one laser is installed, you can select multiple lasers.

9. Enter the light intensity that you want to use in the **Dose** field of the *Characteristics* frame.

It is recommended to test different light intensities beforehand by executing a dose series to determine the most suitable light intensity.

Depending on the job type, the user can change the light intensity in the job setup.

- Enter the focus offset that you want to use in the **Defoc** field of the *Characteristics* frame.

It is recommended to test different focus offsets beforehand by executing a focus offset series to determine the most suitable focus offset.

Depending on the job type, the user can change the focus offset in the job setup.

- If you set up a template for grayscale designs, select **Set individual Doses for each Bitlayer** in the *Grayvalue Optimization* frame.
- ✓ You see a table that shows the light intensities that are assigned to the bit values for the grayscale mode.

Grayvalue Optimization								
<input checked="" type="checkbox"/> Set individual Doses for each Bitlayer								
Bit	128	64	32	16	8	4	2	1
%	50.2	25.1	12.5	6.3	3.1	1.6	0.8	0.4
Dose	100.4	50.2	25.1	12.5	6.3	3.1	1.6	0.8
Total Dose	200.0		Reset Percentages					

Fig. 94: Load Resist frame – Grayvalue Optimization frame

- If you selected **Set individual Doses for each Bitlayer**, enter for each bit value the desired light intensity as a percentage of the maximum light intensity in the **%** row of the *Bit Values* table.

Alternatively, you can set absolute values in the **Dose** row.

If you enter a percentage value, the absolute value is calculated automatically and vice versa.

- If you want to increase the stage movement, enter the factor by which the stage movement is multiplied in the **Speedup Factor** field of the *Exposure Parameters* frame.

Increasing the stage movement can be useful to reduce the exposure time, especially if you expose with high light intensity. But you must consider that faster stage movement reduces the exposure quality.

- If you want to use an extended exposure focus offset, select **Large** from the **Defoc Range** drop-down list in the *Exposure Parameters* frame.

This setting is useful if your application requires to expose deeper into the resist.

The large exposure focus offset increases the focus offset range from [-10 ... 10] to [-25 ... 25].

Note that the exposure focus offset is not related to the camera focus offset that you use for alignment procedures.

- If you want to add information about which developer must be used for developing the image after exposure, enter the information in the **Developer** field of the *Process Parameters* frame.

- If you want to add information about the concentration of the developer, enter the information in the **Concentration** field of the *Process Parameters* frame.

17. If you want to add information about the required developing time, enter the information in the **Develop Time** field of the *Process Parameters* frame.
18. Click **Save** in the *Edit* frame to confirm.
- ✓ The fields in the Characteristics frame and the frames below the *Characteristics* frame are read-only.

Now, the template is saved and you can select the template for setting up a job.

9.3 Set up bitmap templates

Note that you may need extended user access rights to execute the following instruction. For more information about user access rights, contact the system administrator.

Perform the following steps to set up a bitmap template:

1. Create a job.
For more information, see "6.3 Create jobs", page 77.
2. Select **Standard** from the **Exposure Mode** drop-down list in the *Job* frame of the *Setup Job* frame.
In general, the job type that you select is not relevant for creating the template. The job type only needs to support the selection of a bitmap template.
- ✓ You see the *Layer* frame in the *Setup Job* frame.
3. Double-click the field below **Exposure Bitmaps** in the *Layer* frame.
- ✓ The *Load Exposure Bitmaps* frame opens.
4. Create a new template or edit an existing template.
 - If you want to create a new template, click **New** in the *Edit* frame.
 - If you want to edit an existing template, select the template that you want to edit from the *Bitmaps Templates* table and click **Edit** in the *Edit* frame.
If you edit an existing template, you do not need to set all parameters again, but you must carefully check all parameters for correctness and completeness. The steps below support you with the evaluation of the parameters.
- ✓ The fields in the *Expose Bitmap Positions* frame can be edited.
5. Enter the name that you want to set for the template in the topmost cell of the table in the *Expose Bitmap Positions* frame.
6. Select the surface at which you want to expose the bitmaps from the drop-down list in the second cell of the table in the *Expose Bitmap Positions* frame:
 - If you want to expose the bitmaps at the top surface of the substrate, select **Top Surface**.
 - If you want to expose the bitmaps at the bottom surface of the substrate, select **Back Surface**.
7. Enter the position of the first bitmap on the x-axis in the **X** column and the **Pos 1** row of the table in the *Expose Bitmap Positions* frame.

8. Enter the position of the first bitmap on the y-axis in the **Y** column and the **Pos 1** row of the table in the *Expose Bitmap Positions* frame.
 9. Select the bitmap file that you want to use for the first bitmap from the first drop-down list next to the table in the *Expose Bitmap Positions* frame.
 10. If you want to add more bitmaps, repeat the steps 7 to 8.
For example, if you want to add a second bitmap, enter the positions in the **Pos 2** row and select the bitmap file from the second drop-down list, and so on.
If you want to use the same bitmap file for all bitmaps in the table, select **Use first bitmap** for all below the drop-down lists next to the table.
 11. Click **Save** in the *Edit* frame to confirm.
- ✓ The fields in the *Expose Bitmap Positions* frame are read-only.
- Now, the template is saved and you can select the template for setting up a job.

9.4 Set up alignment templates

Note that you may need extended user access rights to execute the following instruction. For more information about user access rights, contact the system administrator.

Note that the following instruction may contain steps related to features, options, or objects that are not available for your system. Skip the steps that are not relevant for you.

Perform the following steps to set up an alignment template:

1. Create a job.
For more information, see "6.3 Create jobs", page 77.
2. Select **Standard** from the **Exposure Mode** drop-down list in the *Job* frame of the *Setup Job* frame.
In general, the job type that you select is not relevant for creating the template. The job type only needs to support the selection of an alignment template.
- ✓ You see the *Layer* frame in the *Setup Job* frame.
3. Double-click the field below **Alignment Settings** in the *Layer* frame.
- ✓ The *Load Alignment Settings* frame opens.
4. Create a new template or edit an existing template.
 - If you want to create a new template, click **New** in the *Edit* frame.
 - If you want to edit an existing template, select the template that you want to edit from the *Alignment Templates* table and click **Edit** in the *Edit* frame.
If you edit an existing template, you do not need to set all parameters again, but you must carefully check all parameters for correctness and completeness. The steps below support you with the evaluation of the parameters.
- ✓ The fields in the *Alignment Settings* frame can be edited.
5. Enter the name that you want to set for the template in the topmost cell of the table in the *Alignment Settings* frame.

6. Select the surface at which the alignment marks are located from the drop-down list in the second cell of the table in the *Alignment Settings* frame:
 - If the alignment marks are located at the top surface of the substrate, select **Top Surface**.
 - If the alignment marks are located at the bottom surface of the substrate, select **Back Surface**.
7. Enter the position of the first alignment mark on the x-axis in the **X** column and the **Pos 1** row of the table in the *Alignment Settings* frame.
8. Enter the position of the first alignment mark on the y-axis in the **Y** column and the **Pos 1** row of the table in the *Alignment Settings* frame.
9. If you want to add more alignment marks, repeat the steps 7 and 8.
For example, if you want to add a second alignment mark, enter the positions in the **Pos 2** row, and so on.
10. Select the camera that you want to use for the alignment procedure from the *Camera for Alignment* frame in the *Alignment Settings* frame.
11. If you want to use the substrate rotation angle, select **Use** next to **Rotation** in the *Alignment Correction Options* frame.
This option is recommended.
The substrate angle represents the rotation of the substrate on the chuck. The system measured the substrate angle during the find center procedure. The alignment is rotated by the substrate angle to compensate the substrate rotation.
The substrate angle is particularly relevant for small substrates, which are usually difficult to load perfectly straight.
12. If you want to scale the aligned design, select **Use** next to **Scaling X/Y** in the *Alignment Correction Options* frame.
This option requires at least 3 measured alignment marks.
The system compares the measured distance between the alignment marks. A scaling factor is calculated from the deviation. Based on the scaling factor, the aligned design is resized to the previous layer.
13. If you want to compensate distortions, select **Use** next to **Shearing** in the *Alignment Correction Options* frame.
The system tries to compensate small distortions, such as rectangles that resemble a parallelogram.
14. If you want to return the stage to the (0/0) position when the alignment is completed, select **Move to Zero after last position**.
15. If you want to execute a field alignment, select **Use Field Alignment** in the *Field Alignment* frame.
16. If you selected **Use Field Alignment**, click **Load** in the *Field Alignment* frame and select a field alignment template.
For more information, see "9.5 Set up field alignment templates", page 154.

17. Click **Save** in the *Edit* frame to confirm.

✓ The fields in the *Alignment Settings* frame are read-only.

Now, the template is saved and you can select the template for setting up a job.

9.5 Set up field alignment templates

Note that you may need extended user access rights to execute the following instruction. For more information about user access rights, contact the system administrator.

Note that the following instruction may contain steps related to features, options, or objects that are not available for your system. Skip the steps that are not relevant for you.

To create a field alignment template, you must start executing a field-aligned exposure. During the setup of the field-aligned exposure, you can set up and save the field alignment template.

Perform the following steps to set up a field alignment template:

1. Create a job.

For more information, see "6.3 Create jobs", page 77.

2. Select **Standard** from the **Exposure Mode** drop-down list in the *Job* frame of the *Setup Job* frame.

In general, the job type that you select is not relevant for creating the template. The job type only needs to support the selection of a bitmap template.

✓ You see the *Layer* frame in the *Setup Job* frame.

3. Add and set up another layer in the *Layer* frame.

For more information, see "8.3.5 Set up layers", page 120.

4. Execute a global alignment.

For more information, see "8.3.8 Execute alignments", page 123.

✓ The *Alignment Exposure* frame opens.

5. Select **Expose the Design several times in a Map using Field Alignment** in the *Field Alignment* frame.

✓ You see additional frames with parameters for the setup of the field alignment in the *Field Alignment* frame.

6. If you want to load an existing field alignment template, click **Load** in the *Load and Save* frame and select the setup that you want to load.

✓ You see parameters of the loaded field alignment setup in the *Map Parameters* frame.

7. Set the number of fields in the **Number of Fields** fields of the *Map Parameters* frame.

- The number of fields on the x-axis represents the number of rows in the grid.
- The number of fields on the y-axis represents the number of columns in the grid.

8. Set the index of the starting field in the **Measure Cross Number** fields of the *Map Parameters* frame.
The starting field is the field at which you want to start the measurement.
9. Set the distance between the fields on that were exposed on the previous layer in the **Step Size** fields of the *Map Parameters* frame.
10. Set the position of the alignment marks within the fields in the **Position of Cross** field of the *Map Parameters* frame.
Note that the position that you set are the x/y-coordinates in the grid cell.
11. Click **Save** in the *Load and Save* frame to save the setup as a field alignment template.

Now, the template is saved and you can select the template for setting up an alignment template. You can continue with executing the field-aligned exposure or you can cancel the field-aligned exposure.

9.6 Set up series templates

Note that you may need extended user access rights to execute the following instruction. For more information about user access rights, contact the system administrator.

Perform the following steps to set up a series template:

1. Create a job.
For more information, see "6.3 Create jobs", page 77.
2. Select **Series** from the **Exposure Mode** drop-down list in the *Job* frame of the *Setup Job* frame.
- ✓ You see the *Series* frame in the *Setup Job* frame.
3. Double-click the field below **Series Template** in the *Series* frame.
- ✓ The *Load Series* frame opens.
4. Create a new template or edit an existing template.
 - If you want to create a new template, click **New** in the *Edit* frame.
 - If you want to edit an existing template, select the template that you want to edit from the *Series Templates* table and click **Edit** in the *Edit* frame.

If you edit an existing template, you do not need to set all parameters again, but you must carefully check all parameters for correctness and completeness. The steps below support you with the evaluation of the parameters.
- ✓ The fields in the *Parameters* frame can be edited.
5. Enter the name that you want to set for the template in the **Series Name** field in the *Parameters* frame.
6. Select the laser that you want to use from the **Laser** drop-down list in the *Parameters* frame.
7. Select the autofocus mode that you want to use from the **Focus Mode** drop-down list in the *Parameters* frame.

8. Select the exposure series mode that you want to use from the **Series Mode** drop-down list in the *Parameters* frame.
 - **Dose:** Select this option to execute a dose series.
The dose increments per field while the focus offset is fixed.
 - **Defoc:** Select this option to execute a focus offset series.
The focus offset increments per field while the dose is fixed.
 - **Dose and Defoc:** Select this option to execute a dose / focus offset matrix.
The dose increments per field on the y-axis and the focus offset increments per field on the x-axis.
9. If you want to set up a dose series or a dose / focus offset matrix, set the following values in the *Dose Series* table:
 1. Set the number of fields that you want to expose per row in the **Number of Fields** field.
 2. Set the starting dose in the **Start Value** field.
 3. Set the increment per field in the **Step Size** field.
Example: If you expose 3 fields with a starting dose of 20 and increment by 10, the first field is exposed with a dose of 20, the second field is exposed with a dose of 30, and the third field is exposed with a dose of 40.
 - ✓ The calculated end value of the series is shown in the **End Value** field.
 4. If you want to adjust the focus position and the focal point of the write head, set the focus offset in the **Fixed Defoc Value** field.
10. If you want to set up a focus offset series or a dose / focus offset matrix, set the following values in the *Defoc Series* table:
 1. Set the number of fields that you want to expose per row in the **Number of Fields** field.
 2. Set the starting dose in the **Start Value** field.
 3. Set the increment per field in the **Step Size** field.
Example: If you expose 3 fields with a starting focus offset of 10 and increment by 5, the first field is exposed with a focus offset of 10, the second field is exposed with a focus offset of 15, and the third field is exposed with a focus offset of 20.
 - ✓ The calculated end value of the series is shown in the **End Value** field.
 4. If you want to adjust the dose, set the dose in the **Fixed Dose Value** field.
11. Set the number of rows that you want to set up in the **Number of Rows** field.
12. Set the distance between the fields on the x-axis in the **Step Size in X** field.
 - ✓ You see the calculated total width in the **Total Range in X** field.
13. Set the distance between the fields on the y-axis in the **Step Size in Y** field.
 - You can set the vertical distance only if you expose more than one row.
 - ✓ You see the calculated total height in the **Total Range in Y** field.

14. Click **Save** in the *Edit* frame to confirm.

✓ The fields in the *Parameters* frame are read-only.

Now, the template is saved and you can select the template for setting up a job.

10 Execute calibrations

Note that you may need extended user access rights to execute the following instruction. For more information about user access rights, contact the system administrator.

If you notice small offsets of less than 1 μm in multi-layer exposures, it may be necessary to calibrate the beam offset.

NOTE

If you notice larger offsets of more than 1 μm , double-check your alignment marks and the position of the alignment marks.

In case of questions or if the issue persists, contact the Heidelberg Instruments Mikrotechnik Customer Service.

To calibrate the beam offset, you expose 2 specific designs each of which contains a part of a test pattern:

- *Design 1*: HIMT_BeamOffset1
- *Design 2*: HIMT_BeamOffset2

Design 1 contains a Vernier scale that allows an accurate measurement reading. *Design 2* mirrors the Vernier scale. It is important to expose the 2 designs on different layers so you can read the deviation on the x-axis and the y-axis between *Design 1* and *Design 2*.

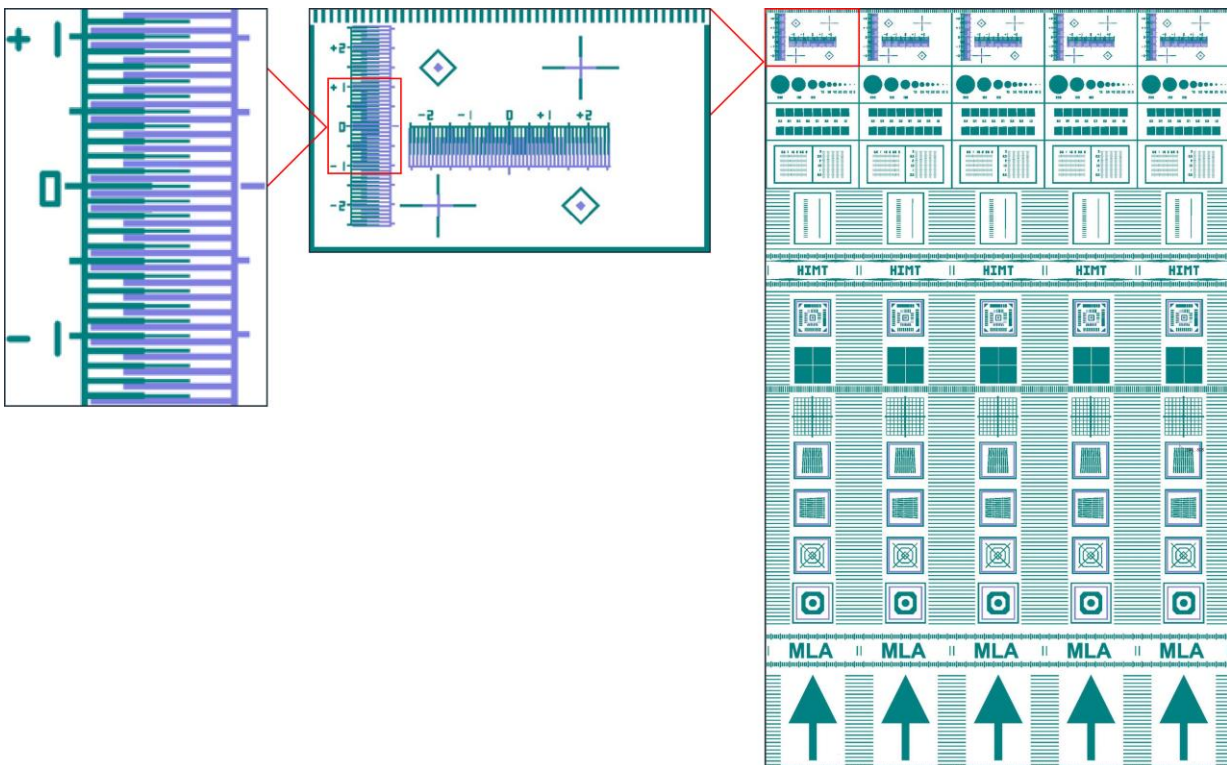

Fig. 95: Vernier scale in FAT test pattern

The designs are delivered with the system and are available in the Designs table of the Load Designs frame. You expose *Design 1* on the first layer and *Design 2* on the second layer by executing a regular multi-layer exposure.

Perform the following steps to execute a beam offset calibration:

1. Expose the 2 designs with the test patterns for the beam offset on 2 different layers on the substrate.

For more information, see "8.2 Execute multi-layer exposures", page 95.

Complete the following steps to expose the 2 designs:

1. Set up a job.
 2. Select the design HIMT_BeamOffset1 for the first layer.
 3. Expose the first layer.
 4. Add a new layer.
 5. Select the design HIMT_BeamOffset2 for the second layer.
 6. Align the second layer with the first layer.
 7. Expose the second layer.
- ✓ The exposure of the 2 layers is completed.
 - ✓ The design HIMT_BeamOffset1 is exposed on the first layer.
 - ✓ The design HIMT_BeamOffset2 is exposed on the second layer.
2. Create a new job.

For more information, see "6.3 Create jobs", page 77.
 3. Select **Inspection** from the **Exposure Mode** drop-down list in the Job frame of the Setup Job frame.
 4. Double-click the field below **Substrate Template** in the Substrate frame.
- ✓ The Load Substrate frame opens.
5. Select the substrate template that you want to use from the Substrate Templates table.

If you do not want to use a substrate template, set the parameters of the substrate that you want to use in the Characteristics frame and, if required, in the Advanced Parameters frame.
 6. Click **Load** in the Load frame to confirm.
- ✓ The Setup Job frame opens.
 - ✓ You see the parameters of the substrate in the Substrate frame.
7. Click **Inspection** in the Proceed frame of the Setup Job frame.
- ✓ The Inspection Mode frame opens.
8. Use the arrow buttons in the Stage Control frame to move to the stage to the position of the horizontal Vernier scale in the test pattern.

9. Read the deviation on the x-axis from the Vernier scale.
It is recommended to note the value because you need the values in a later step.
 - ✓ You have measured the deviation on the x-axis.
10. Use the arrow buttons in the Stage Control frame to move to the stage to the position of the vertical Vernier scale in the test pattern.
11. Read the deviation on the y-axis from the Vernier scale.
It is recommended to note the value because you need the values in a later step.
 - ✓ You have measured the deviation on the y-axis.
12. Select **Tools » Beam Offset** from the menu bar.
 - ✓ The *Beam Offset* dialog box opens.
13. Enter the deviation that you measured for the x-axis in the **Displacement X** field.
14. Enter the deviation that you measured for the y-axis in the **Displacement Y** field.
 - ✓ The system automatically calculates the current beam offset and the target beam offset that will be applied during the calibration.
 - ✓ You see the calculated beam offset in the **Current Offset X** and **Current Offset Y** fields.
 - ✓ You see the target beam offset in the **New Offset X** and **New Offset Y** fields.

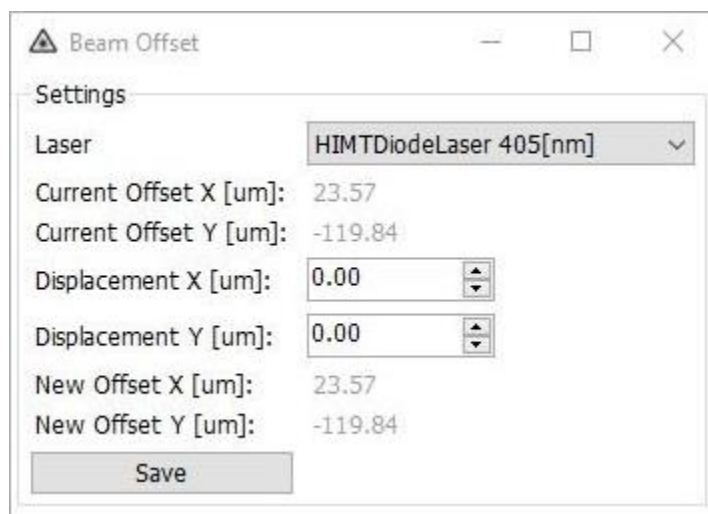

Fig. 96: Beam Offset dialog – Calculated beam offset

15. Click **Save** to apply the calculated target beam offset.
 - ✓ The *Beam Offset* dialog closes.
 - ✓ The calculated target beam offset is applied.

Now, the beam offset calibration is completed.

11 Troubleshooting

PROBLEM: THE EXPOSURE DOES NOT START

Possible cause 1: The loading window is not completely closed.

Possible solution:

1. Open and close the loading window.
2. Make sure that the loading window is completely closed.

Possible cause 2: The system may be unresponsive.

Possible solution:

1. Restart the control software.
2. If the issue persists, restart the system.

Possible cause 3: The exposure laser is switched off or malfunctioning.

Possible solution:

1. Check if the **On** LED for the relevant laser lights up yellow at the operator panel.
2. Contact your local Heidelberg Instruments Mikrotechnik Customer Service Center for assistance.

PROBLEM: THE EXPOSURE IS NOT VISIBLE ON THE SUBSTRATE

Possible cause: The exposure laser is switched off or malfunctioning.

Possible solution:

1. Check if the **On** LED for the relevant laser lights up yellow at the operator panel.
2. Contact your local Heidelberg Instruments Mikrotechnik Customer Service Center for assistance.

PROBLEM: THE EXPOSURE STOPS UNEXPECTEDLY

Possible cause 1: The imaging area settings are not suitable and the system reached an end switch.

Possible solution:

- Double-check the image area settings.

Possible cause 2: The issue is caused by the conversion process.

Possible solution:

1. Open the design in the conversion software.
2. Check the settings of the design.
3. Convert the design again.

Possible cause 3: The interferometer is malfunctioning and needs repairing.

Possible solution:

- Contact your local Heidelberg Instruments Mikrotechnik Customer Service Center.

PROBLEM: THE THICKNESS OF THE EXPOSED LINES IS INCORRECT

Possible cause 1: The dose or focus offset settings are not suitable.

Possible solution:

1. Double-check the dose and focus offset settings.
2. If the issue persists, execute an exposure series to test if other settings give better results.

Possible cause 2: The issue is caused by the resist.

Possible solution:

1. Make sure that the resist is suitable for the application.
2. Make sure that the resist thickness is suitable for the application.

Possible cause 3: The issue is caused by the developing process.

Possible solution:

1. Make sure that the developer is suitable for the resist.
2. Make sure that the developing time is suitable for the resist thickness.
3. Make sure that the developer is not expired.

PROBLEM: THE ALIGNMENT QUALITY IS INSUFFICIENT

Possible cause 1: The environmental temperature is not stable.

Possible solution:

1. Check the temperature of the environmental chamber at the temperature controller display.
The temperature in the environmental chamber should be equal to the temperature of the cleanroom.
2. If the issue persists, monitor the temperature of the environmental chamber and the clean room for a longer period.
3. In case of significant fluctuations, take measures to ensure better temperature stability.

Possible cause 2: Vibrations are transferred to the substrate.

Possible solution:

1. Check if the vacuum quality is sufficient and that no vibrations are transferred via the vacuum.
2. Check the stage for vibrations.

Possible cause 3: The interferometer is malfunctioning and needs repairing.

Possible solution:

1. To identify this cause, check for drifts in position measurement with the stage standing still in the home position.
If drifts are noticeable, the interferometer is malfunctioning.
2. Contact your local Heidelberg Instruments Mikrotechnik Customer Service Center.

PROBLEM: THE WAFER EDGES ARE SCRATCHED

Possible cause: The issue is caused by resist edge beads.

Possible solution:

- Make sure to remove any edge beads on the wafer surface before you process the substrate.

The resist coating on the wafer surface should be as even as possible.

PROBLEM: THE CONNECTION TO THE CAMERA IS LOST

Possible cause: The issue can have various causes.

Possible solution:

If the connection to the camera is lost, a dialog box opens that asks you if you want to reconnect the camera.

1. Click **Yes** in the dialog box.
2. To test the camera connection, click any camera-related button in the control software.

If the camera is reconnected, another dialog informs you that the connection was successfully established.

PROBLEM: THE CAMERA SOFTWARE IS UNRESPONSIVE

Possible cause: The issue can have various causes.

Possible solution:

1. Close the camera software by using the small window.
2. To restart the camera software, click any camera-related button in the control software.
3. If a connection to the camera needs to be established, a dialog box opens that asks you if you want to reconnect the camera.
4. Click **Yes** in the dialog box.
5. To test the camera connection, click any camera-related button in the control software.

If the camera is reconnected, another dialog informs you that the connection was successfully established.

PROBLEM: MEMORY SPACE ISSUES OCCUR

Possible cause: The issue can have various causes.

Possible solution:

If memory space issues occur, it is possible to limit the data logging of the system. This procedure should only be executed in cooperation with a Heidelberg Instruments Mikrotechnik service engineer.

1. Contact your local Heidelberg Instruments Mikrotechnik Customer Service Center.
2. Follow the instructions of the Heidelberg Instruments Mikrotechnik service engineer to change the data logging settings of the system.